



IP-200PHD

2.0 Mega Pixel Passive PoE
IPCamera

User's Manual



www.airlive.com



Copyright & Disclaimer

No part of this publication may be reproduced in any form or by any means, whether electronic, mechanical, photocopying, or recording without the written consent of OvisLink Corp.

OvisLink Corp. has made the best effort to ensure the accuracy of the information in this user's guide. However, we are not liable for the inaccuracies or errors in this guide. Please use with caution. All information is subject to change without notice.

All Trademarks are properties of their respective holders.



FCC Statement

Federal Communication Commission Interference Statement This equipment has been tested and found to comply with the limits for a Class B digital device, pursuant to Part 15 of the FCC Rules.

These limits are designed to provide reasonable protection against harmful interference in a residential installation. This equipment generates, uses and can radiate radio frequency energy and, if not installed and used in accordance with the instructions, may cause harmful interference to radio communications. However, there is no guarantee that interference will not occur in a particular installation. If this equipment does cause harmful interference to radio or television reception, which can be determined by turning the equipment off and on, the user is encouraged to try to correct the interference by one of the following measures:

- Reorient or relocate the receiving antenna.
- Increase the separation between the equipment and receiver.
- Connect the equipment into an outlet on a circuit different from that to which the receiver is connected.
- Consult the dealer or an experienced radio/TV technician for help.

FCC Caution

Any changes or modifications not expressly approved by the party responsible for compliance could void the user's authority to operate this equipment.

This device complies with Part 15 of the FCC Rules. Operation is subject to the following two conditions: (1) This device may not cause harmful interference, and (2) this device must accept any interference received, including interference that may cause undesired operation. For product available in the USA/Canada market, only channel 1~11 can be operated. Selection of other channels is not possible.

This device and its antenna(s) must not be co-located or operation in conjunction with any other antenna or transmitter.

IMPORTANT NOTE

FCC Radiation Exposure Statement:

This equipment complies with FCC radiation exposure limits set forth for an uncontrolled environment. This equipment should be installed and operated with minimum distance 20cm between the radiator & your body.



Bluetooth

© 2009 OvisLink Corporation, All Rights Reserved

Table of Contents

1. Introduction	5
1.1 Overview	5
1.2 Features	6
1.3 System Requirements	6
1.4 Package Contents	7
1.5 Physical Description	7
1.5.1 Front View	7
1.5.2 Bottom View	8
1.6 Hardware Installation	9
2. Getting Started	12
2.1 IP Wizard	12
2.1.1 View	14
2.1.2 LAN	14
2.2 UPnP for Windows	16
2.3 Install the IP Camera behind NAT router	17
2.4 Configure IP Camera via Web UI	18
2.4.1 Login as User	19
2.4.2 Login as Administrator	20
3. Configure the Camera	21
3.1 Monitor the Image Section	21
3.2 View Profile	21
3.3 Streaming Protocol	21
3.4 Language	21
3.5 Two-Way Audio	21
3.6 Full Screen	22
3.7 Active Control	22
3.7.1 Digital Zoom	23
3.7.2 Snapshot	24
3.7.3 Record	24
3.7.4 Volume	25
3.7.5 About	26
4. Monitor the Image Section	27
4.1 Monitor the Image Section	27
4.2 Configure via Web UI	28
4.2.1 Network	28

4.2.2	DDNS	30
4.2.3	PPPoE	32
4.2.4	Steaming	33
4.2.5	UPnP	34
4.2.6	Bonjour	36
4.2.7	IP Filter	37
4.2.8	IP Notification	37
4.3	Camera – Adjust Camera Parameters	40
4.3.1	Picture	40
4.3.2	Privacy Mask	41
4.4	System – Configure and Maintain	43
4.4.1	System	43
4.4.2	Date & Time	45
4.4.3	Maintenance	46
4.5	Video – Configure Profile	48
4.5.1	Common	49
4.5.2	Video Profile	50
4.5.3	ROI	52
4.6	Audio – Audio Parameters	52
4.6.1	Setting	52
4.6.2	Manage User Name, Password and Login Privilege	53
4.6.3	E-Mail	54
4.6.4	Object Detection	55
4.6.5	Storage – Status and Configuration of SD card	57
4.6.6	Recording List- Files List Inside SD Card	58
4.6.7	Event Sever	58
4.6.8	Event Schedule	63
5.	Troubleshooting & FAQ	69
5.1	Monitor the Image Section	69
5.2	PING	75
5.3	Bandwidth Estimation	76
5.4	Specification Table	77
5.5	Configure Port Forwarding Manually	79
5.6	DDNS	82
5.7	Power Line Frequency	89
5.8	3GPP Table	91
5.9	UPnP	92

1

Introduction



IP-200PHD

1.1 Overview

This camera is an inexpensive and fully scalable surveillance device. Because the Network Cameras can be plugged into your existing local area network (LAN), you will potentially save thousands of dollars from unnecessary cabling.

The device is accessible via the LAN or Internet connection. Connect your device directly to a local area network or xDSL modem, and with Microsoft® Internet Explorer you get instant, on demand video streams. Within minutes you can set up the device to capture a video sequence to a PC. The live video can be uploaded to a website for the world to see.

1.2 Features

- Easy installation with setup wizard (IP Wizard II)
- UPnP device discovery and NAT router transversal for easy installation
- Dynamic IP Service, DIPS®, to search your IP camera from Internet easily
- H.264, MPEG4 and JPEG triple compression simultaneously
- 2 Mega-pixel resolution
- Up to 9-profile encoder simultaneously
- 2 Mega-pixel or 720P mode selectable
- Up to 30 fps for 720P mode
- Up to 15 fps for 2 Mega-pixel mode
- UDP / TCP / HTTP protocols selectable
- Passive PoE support
- 3GPP for 3G mobile remote application
- Digital zoom
- Built-in microphone
- Audio line out
- Two-way audio
- Intelligent motion detection up to 10 zones
- Go to preset once motion triggered
- Image transmission using an FTP or e-mail for event
- DDNS and PPPoE
- Multi-channel control software for surveillance application
- On-line firmware upgrade

1.3 System Requirements

- Microsoft Internet Explorer 6.0 or later
- Microsoft Media Player 11.0 or later (to playback recorded file)
- VGA Monitor resolution 1280 x 1024 or higher
- Pentium-4 3.6 GHz or higher
- Memory Size: 1GB or more
- Windows XP, Vista, 7

1.4 Package Contents

User can find the following items in the package:

- **This camera** is the main element of the product.
- **Camera Stand** with screws
- **Power adapter** dedicates 12V DC electric power output to Network Camera.
- **User's manual CD** provides important information and instructions for operating the Network Camera.
- **Quick start guide** provides important information and instructions for installing this device.
- **PoE Accessory (PoE-1P)** provides to connect to a network device and not need to use additional DC injector.

If any of the above items are missing, please contact your dealer immediately.

Note: Using a power supply with a different voltage than the one included with the Network Camera will cause damage and void the warranty for this product.

1.5 Physical Description

1.5.1 Front View



1. Lens & Focus Ring

User could use this ring to adjust focus manually.

2. Microphone

The Camera has built-in an internal microphone. This microphone is hidden in the pinhole located on the front panel.

3. Micro SD Card Slot

User can insert a micro SD card into this slot for event recording.

Note: The product picture is WN-200HD and IP-200PHD without the antenna.

1.5.2 Bottom View

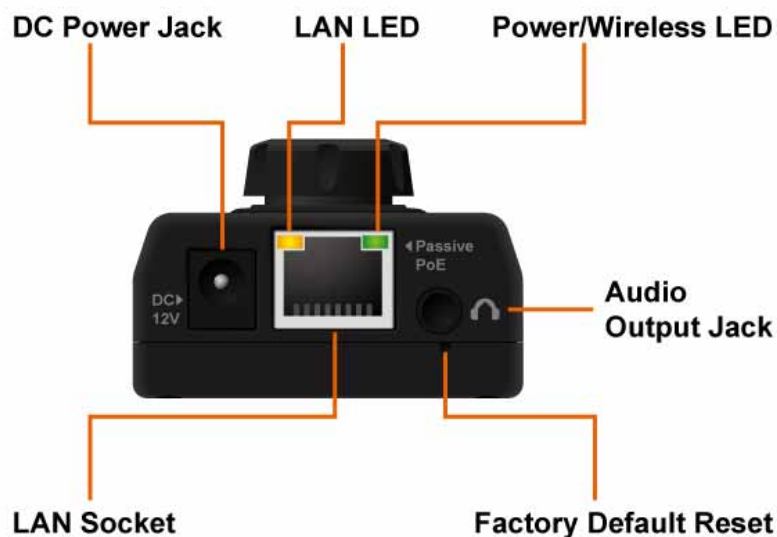

1. Audio Output Jack

Audio-out Jack allows this device to output audio or alerting sound.

2. DC Power Jack

The input power is 12VDC.

Note that supply the power to the Camera with the power adapter included in package. Otherwise, the improper power adapter may damage the unit and result in danger.

3. Factory Default Reset

This button is hidden in the pinhole. This button is used to restore the all factory default settings. Sometimes restarting the camera will make the system back to a normal state. If the system still got problems after restart, user can restore the factory default settings and install it again. To restore the device, please follow the steps below:

- (1) Insert the paper clip or other tool and press and hold the button down continuously.
- (2) Hold it at least 5 seconds and release the tool. Then the device has been restored to default settings and reboot again.

Note: Restoring the factory default setting will lose the all previous settings included IP address forever. User needs to run the IPWizard II program to search the device and configure it to let the device work properly again.

4. LAN Socket

The LAN socket is a RJ-45 connector for connections to 10Base-T Ethernet or 100Base-TX Fast Ethernet cabling. This Ethernet port built N-Way protocol can detect or negotiate the transmission speed of the network automatically. Please use Category 5 cable to connect the Network Camera to a 100Mbps Fast Ethernet network switch or hub.

5. LAN LED (green color)

This LED will be flashing while network accessing via Ethernet.

6. Power LED (orange color)

This LED is used to indicate whether DC power is on or not.

1.6 Hardware Installation

1. Attach the Camera with the included stand
2. Place the Camera on the table or fix it onto ceiling or wall

Use three screws to fix the Network Camera onto the ceiling or wall. You could also put the Network Camera on the table directly.

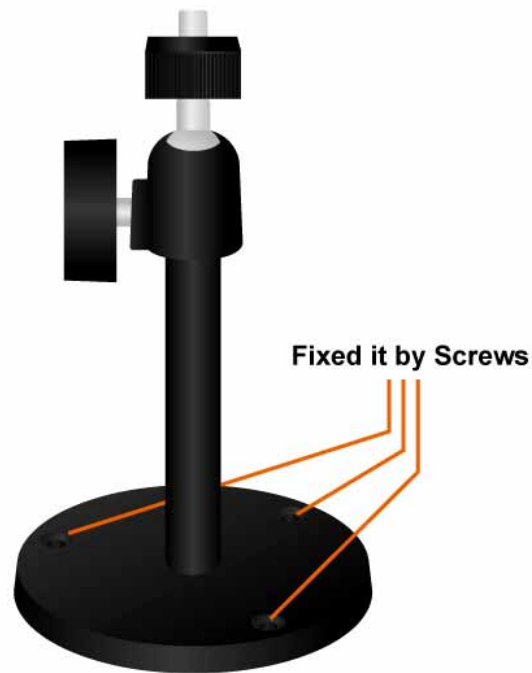

3. Plug an Ethernet cable into the Camera
Connect an Ethernet cable to the LAN socket located on the Network Camera's bottom and attach it to the network.

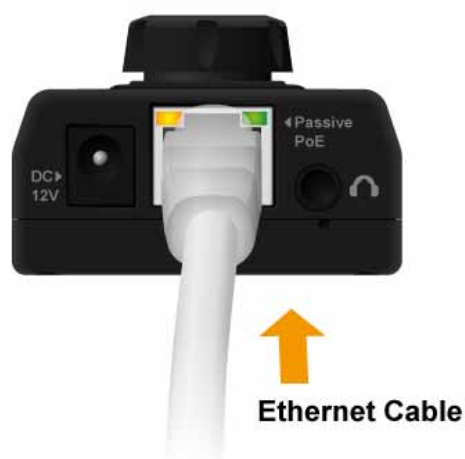

4. Connect the external power supply to Camera
Connect the attached power adapter to the DC power jack of the Network Camera.

Note: Use the power adapter, 12VDC, included in the package and connect it to wall outlet for AC power.

5. Use PoE-1P to connect to a network device (for IP-200PHD only)
The IP-200PHD is using DC 12V passive PoE and you can use PoE-1P as PoE splitter or PoE injector to connect to your network device and there is no need additional power adapter.

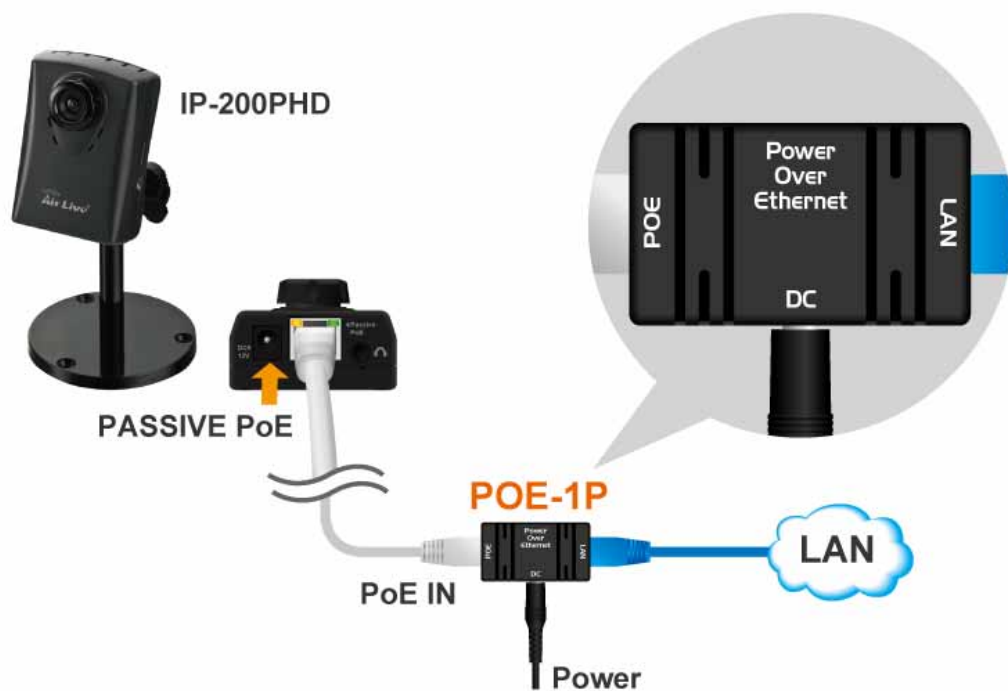

2

Getting Started

2.1 IP Wizard



Once you have installed the Network Camera well and powered it on, the network accessing type LED will turn on. It means the system is booting up successfully. Furthermore, if you have a proper network connection, and access to the Network Camera, the LED will flash green under wired mode.

When you installed the Camera on a LAN environment, you have two easy ways to search your Cameras by IPWizard II or UPnP™ discovery. Here is the way to execute IPWizard II to discover Camera's IP address and set up related parameter in a Camera.

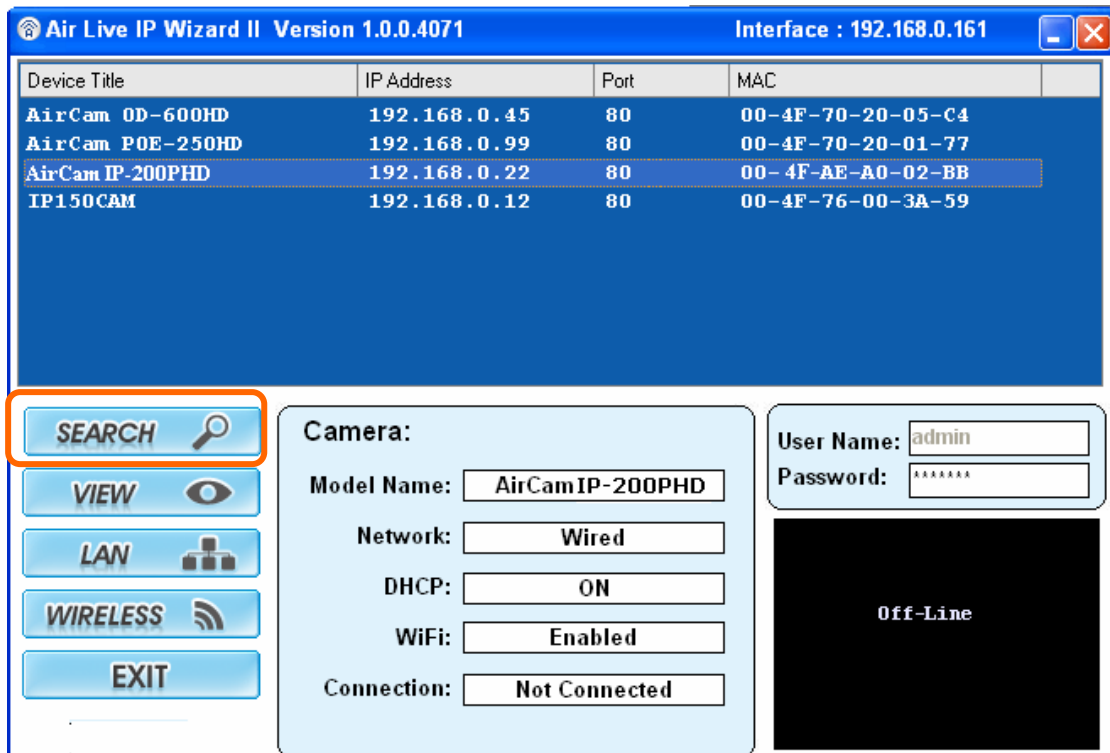

When launch the IPWizard II, a searching window will pop up. IPWizard II is starting to search Network Cameras on the LAN. The existed devices will be listed as below.

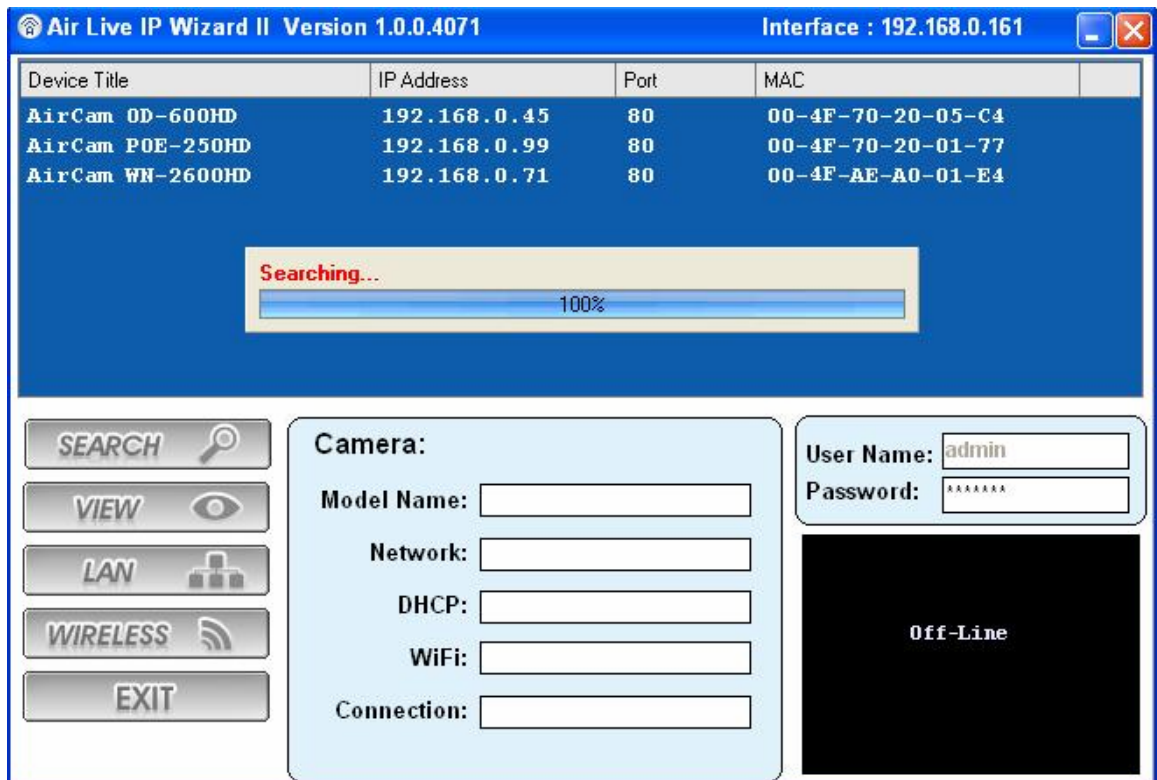

2.1.1 View

If IPWizard II finds network devices, **View** button will be available. Please select the device you want to view and click the **View** button. Then you could see the video from camera directly. Furthermore you could double click the left button of mouse to link to the network device by browser.

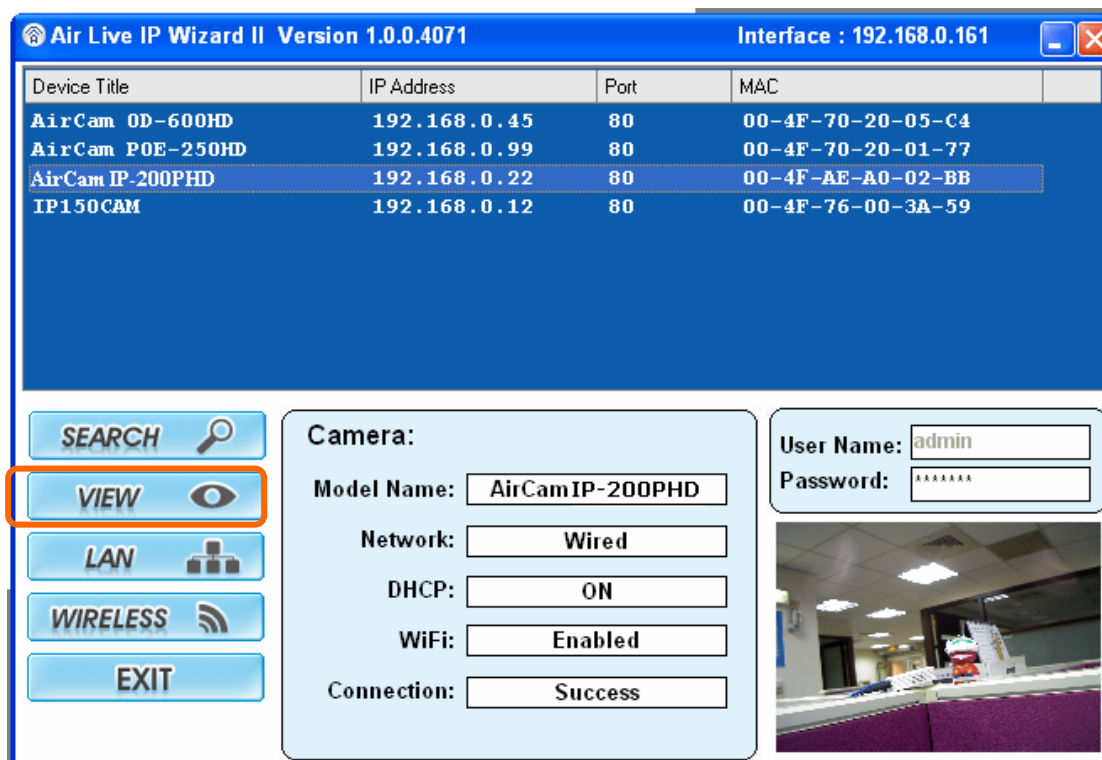

2.1.2 LAN

In case you want to change the IP related parameters of wired interface, please select the device you want to configure and click the **LAN** button. Relative settings will be carried out as below.

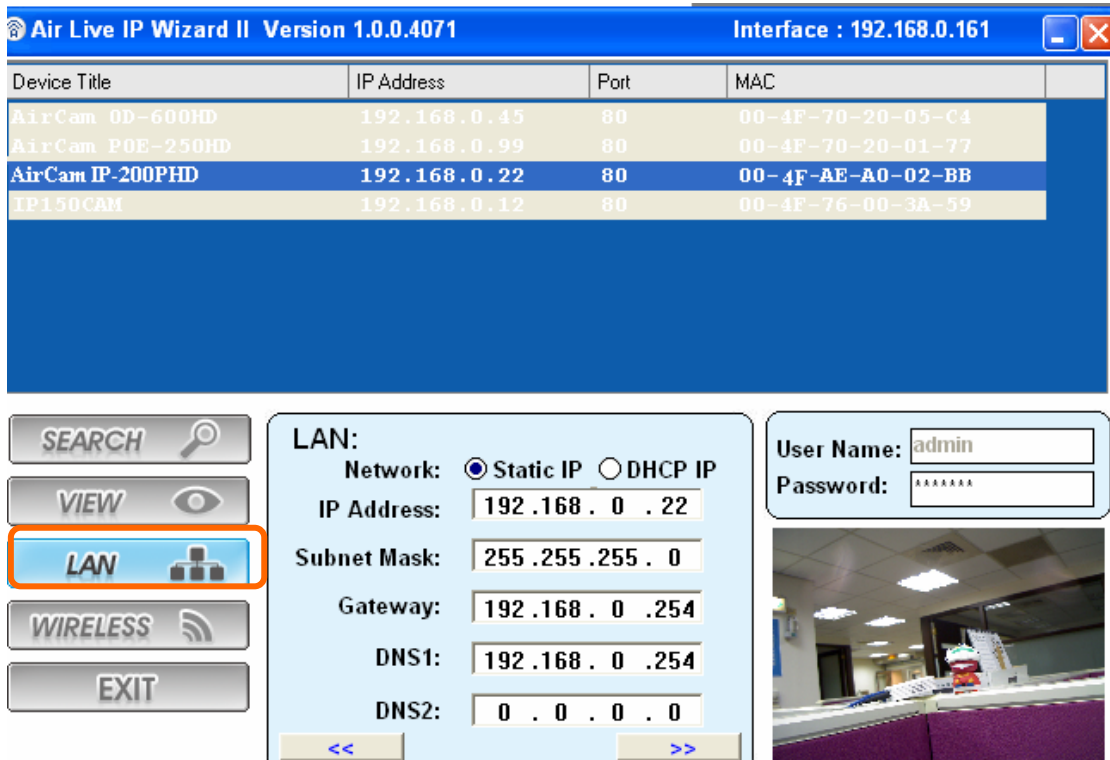

You could modify the relative settings of the selected device. Click “<<” button will quit the LAN setting procedure and click “>>” button will move to next page as below.

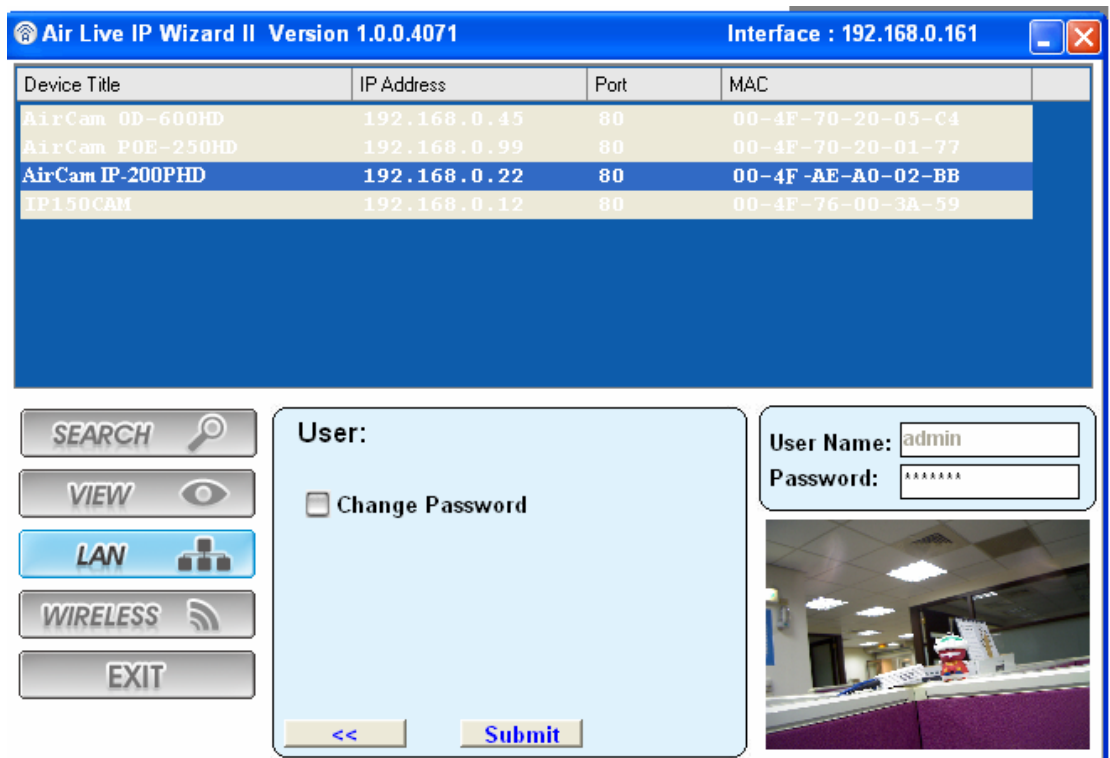

In case, you do not want to change username and/or password, then just click “**Submit**” button to perform your setting accordingly. Click “<<” button will go back to previous page.

If you like to change username and/or password of the device, just click the check button. Then, the related fields will show up as below.

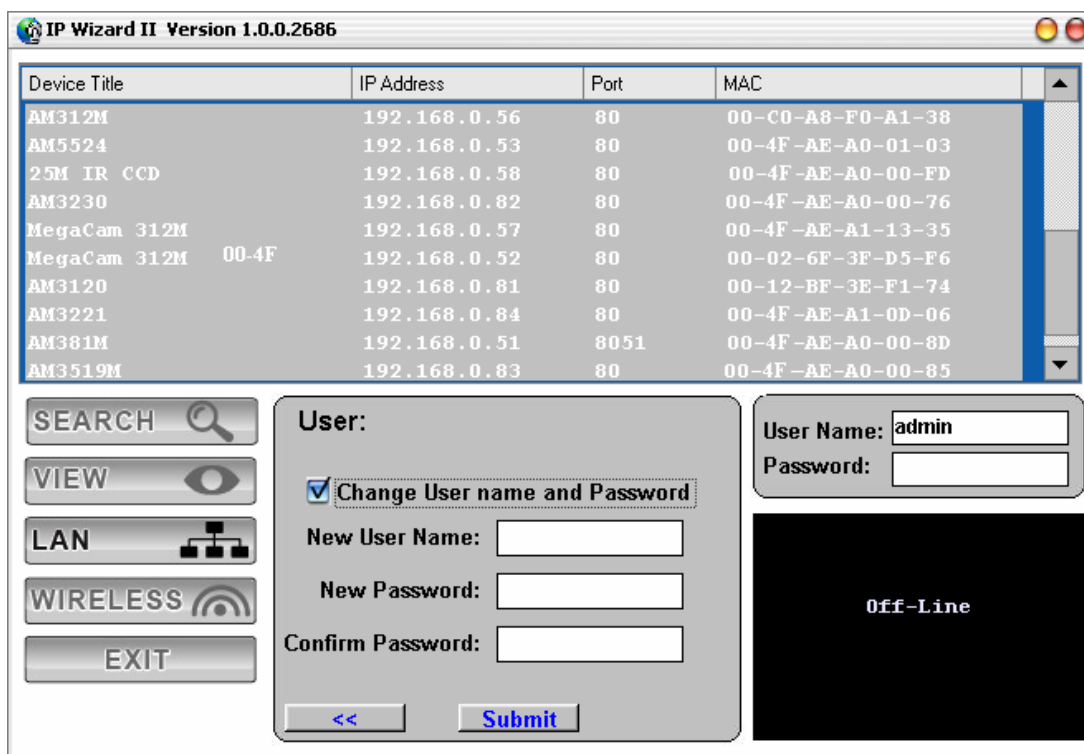

After keying in new username and password, click “**Submit**” button to perform your setting accordingly. Click “<<” button will go back to previous page.

2.2 UPnP for Windows

UPnP™ is short for Universal Plug and Play, which is a networking architecture that provides compatibility among networking equipment, software, and peripherals. This device is an UPnP enabled device. If the operating system, Windows XP, Vista or 7, of your PC is UPnP enabled, the Network Camera will be very easy to be found.

Please refer to Appendix I to enable UPnP settings only if your operating system of PC is running Windows XP.

Note: Windows 2000 does not support UPnP feature.

To discover your device, go to your Desktop and click **My Network Places**.

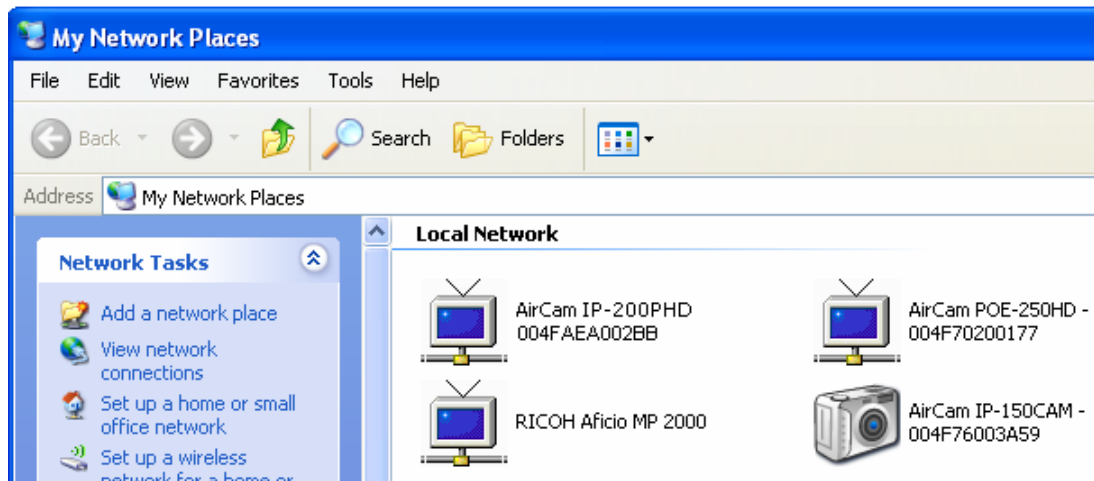

Click the targeted **Device**. Then Internet Explorer will connect to this Network Camera automatically.

2.3 Install the IP Camera behind NAT router

Once installed, the device is accessible on your LAN. To access the device from the Internet you must configure your broadband router to allow incoming data traffic to the device. If the device is installed on the LAN with a router, then it may get a dynamic IP address from the DHCP server. However, if the device wants to be accessed from the WAN, its IP address needs to be setup as fixed IP, also the port forwarding or Virtual Server function of router needs to be setup.

However, if your NAT router supports UPnP feature, it can be very easy to achieve NAT traversal automatically. To do this, enable the NAT-traversal feature, which will attempt to automatically configure the router to allow access to the camera.

Installing the device with an UPnP router on your network is an easy 3-step procedure:

- (1) Enable UPnP option of your NAT router
- (2) Enable UPnP NAT traversal option of the Network Camera (default)
- (3) Access your Network Camera by DIPS

(1) Enable UPnP option of your NAT router

To use UPnP IGD function (NAT traversal), you need to make sure the UPnP function is enabled in your router. Most new home routers should support this function. Some of routers are default enable and others are not. Please check user's manual of your NAT router for detail.

(2) Enable UPnP NAT traversal option of the Network Camera

Refer to **Setting** → **Network** → **UPnP** page for detail NAT traversal setting. Note that this option is default enabled.

(3) Access your Network Camera by DIPS

Refer to **Setting** → **System** → **System** page for detail DIPS information.

2.4 Configure IP Camera via Web UI

1. Start the web browser on the computer and type the IP address of the Camera you want to monitor as below:



The Login Window of the Camera is prompted:



2. Type in your login name and password under “USERNAME” and “PASSWORD” textbox. For the first time use (default value), input the

User Name: **admin**

Password: **airlive**

That's, type in “**admin**” on the “USERNAME” as a default name and “**airlive**” on the “PASSWORD” as a default password. Click “OK” button to start the main menu.

3. According your browser's security setting, the IE Web Page may prompt the “Security Warning” window. If so, select “Yes” to install and run the ActiveX control into your PC. Otherwise, the system will load the ActiveX silently.

4. After the ActiveX control was installed and ran, the first image will be displayed.

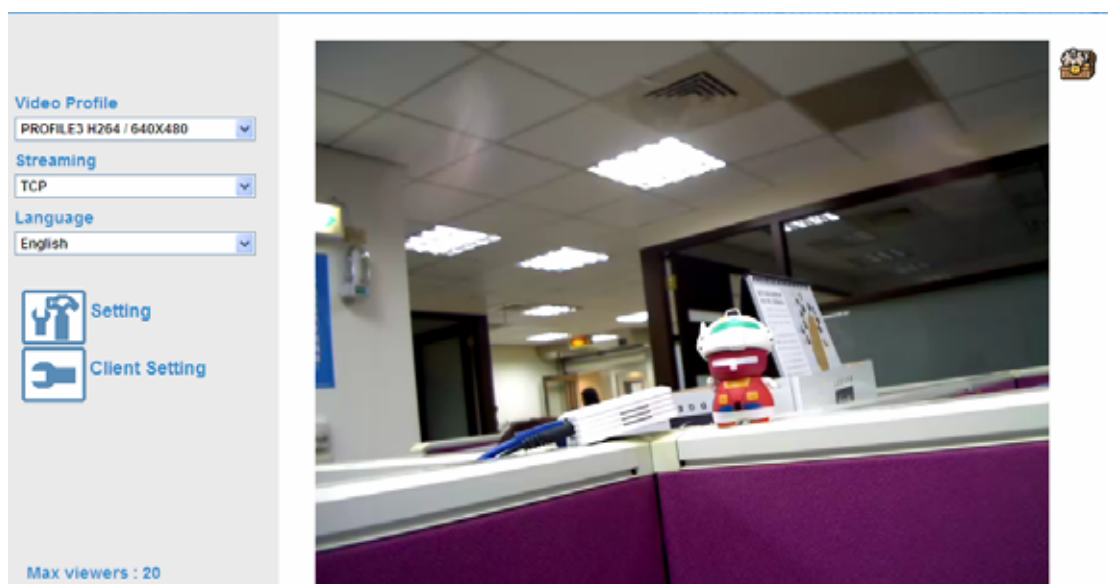

2.4.1 Login as User

If you log in the Camera as an ordinary User, “Setting” function will be not accessible.

2.4.2 Login as Administrator

If you log in the Camera as the Administrator, you can perform all the settings provided by the device.

Start-up screen will be as follow no matter an ordinary users or an administrator.

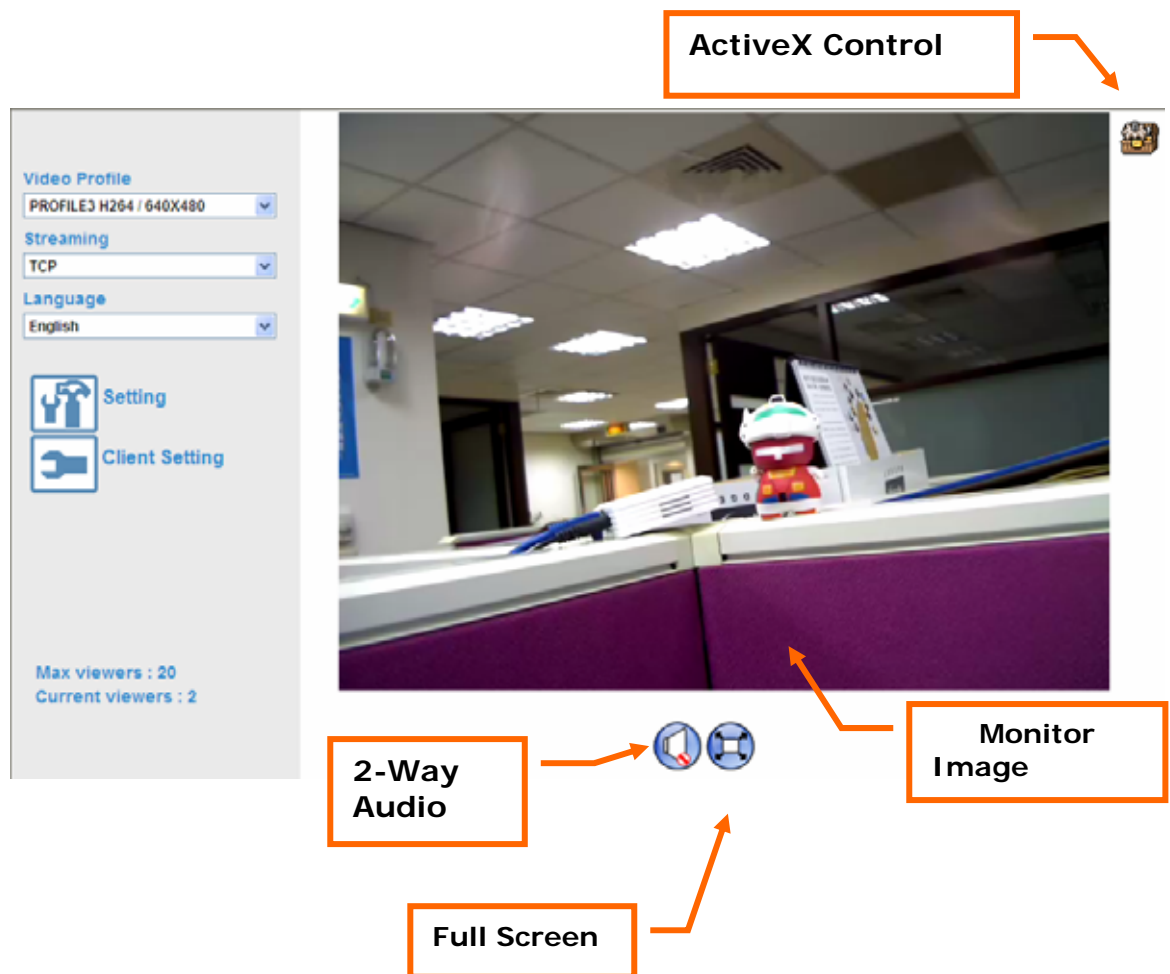

3

Configure the Camera

3.1 Monitor the Image Section

The image shot by the device is shown here. The date and time are displayed at the top of the window.

3.2 View Profile

The device supports multi-profile function for H.264, MPEG4 and JPEG simultaneously. User can chose the proper and/or preferred profile which is listed here.

3.3 Streaming Protocol

User can select proper streaming protocol according to networking environment.

3.4 Language

The device could provide multiple languages to meet customer's requirement.

3.5 Two-Way Audio

The device supports 2-way audio function. User can chose to enable or disable this function by toggling the icon below.



: Disable audio uploading function.



: Enable audio uploading function.

3.6 Full Screen

Enlarge video to full screen display.



: Enlarge video to full screen display. Press “ESC” key to disable this function.

3.7 Active Control

The plug-in ActiveX control supports a lot of functions by clicking the left mouse button. Note that this feature only supports on the ActiveX control within Microsoft® Internet Explorer.

On the ActiveX control icon, click the LeftMouseButton, then a menu pop-up. This menu provides features that are unique to the ActiveX control. These features include:

- “Digital Zoom”,
- “Snapshot”,
- “Record”,
- “Volume”,
- “About”



3.7.1 Digital Zoom

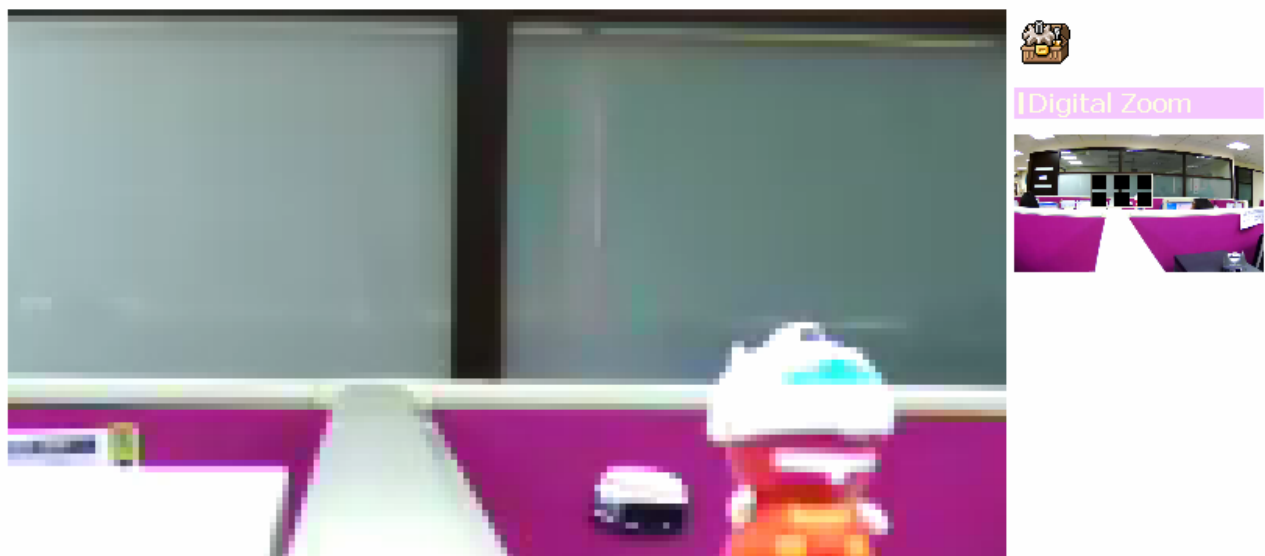

Click **Digital Zoom** to activate this function as above. User can drag or scale the box over the video to adjust zoom ratio and position.

3.7.2 Snapshot



Click **Snapshot** to activate this function. Press **Snapshot** button to take a picture. The image file is saved as JPEG format into your local PC. Select **Browser**, the pop-up window to select the save path and file name prefix, select **OK** to continue.

If you like to retrieve the saved image, select the file to display the saved image by using any one of graph editing tools.

3.7.3 Record



Click **Record** to activate this function. Press **Record** button to start recording. The video file is saved as ASF format into your local PC. While you want to stop it, press **Stop** to stop recording. Select **Browser**, the pop-up window to select the save path and file name prefix, select **OK** to continue.

After stop recording, list the files, this file is named as Video_yyyymmddhhmmss.avi

The ASF files can be display by the standard Windows Media Player, but it needs the DixectX 9.0 or later version to be installed.

3.7.4 Volume

Click **Volume** to activate this function. There are two control bars for speaker and microphone volume respectively. Scroll these control bars to adjust the audio attribute. Check the volume mute will mute the speaker output.



3.7.5 About

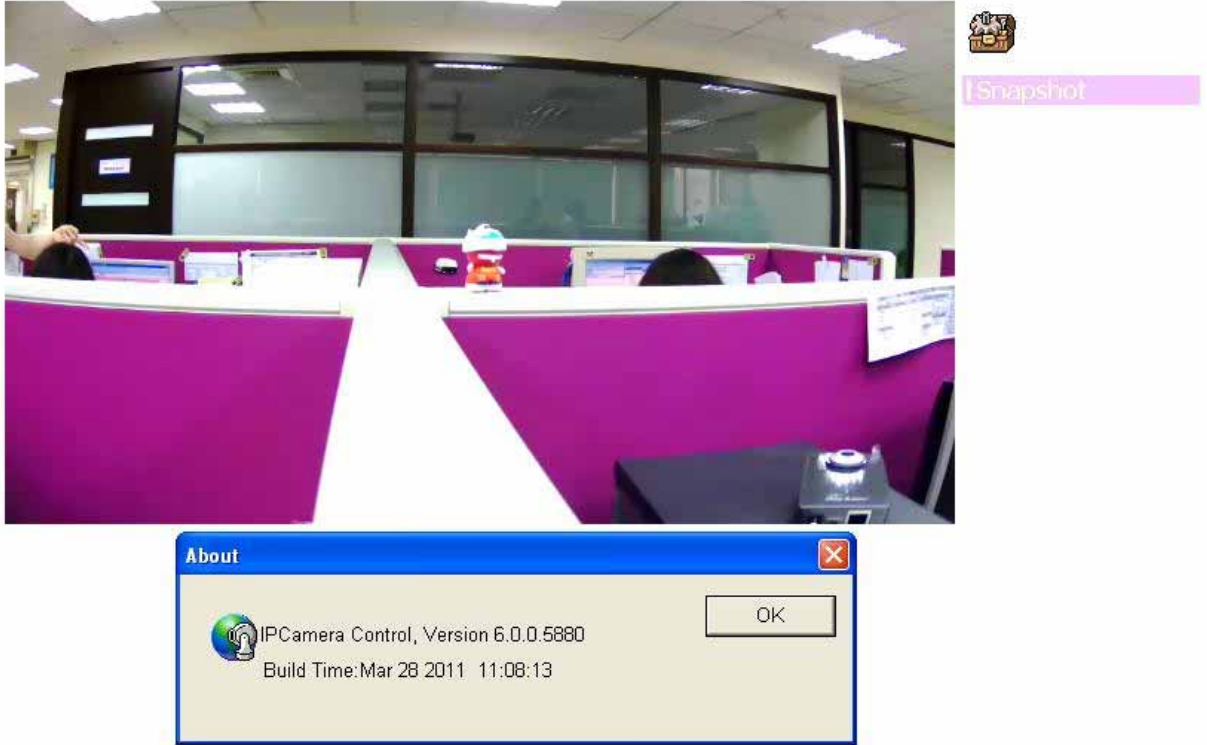

Click **About** to show this ActiveX information.

4

Monitor the Image Section

4.1 Monitor the Image Section

This function is only available for user logged into Camera as administrator.

Click on each menu name to display its setting page.

Item	Action
Network	Configure Network settings such as DHCP, DDNS, 3GPP, PPPoE and UPnP
Camera	Adjust camera parameters, position, and set camera tour
System	Configure system information, date & time, maintenance, and view system log file.
Video	Configure bit rate and frame rate of video profiles
Audio	Configure audio parameters
User	Setup user name, password and login privilege
E-Mail	Setup E-Mail configuration
Object Detection	Setup Object detection
Storage	Status and configuration of SD card
Recording List	Files list inside the SD Card
Event Server	Setup FTP/TCP/HTTP server for event
Event Schedule	Configure the schedule while event triggered

4.2 Configure via Web UI

4.2.1 Network

Use this menu to configure the network to connect the device and the clients. This section provides the menu for connecting the device through Ethernet cable.

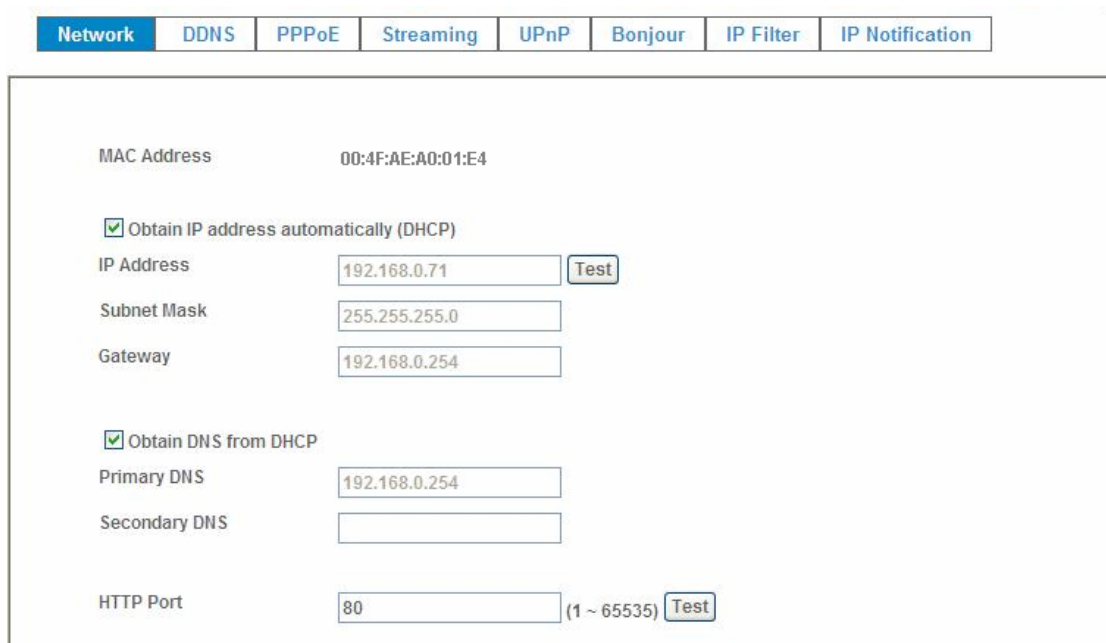

Network	DDNS	PPPoE	Streaming	UPnP	Bonjour	IP Filter	IP Notification
---------	------	-------	-----------	------	---------	-----------	-----------------

MAC Address	00:4F:AE:A0:01:E4
<input checked="" type="checkbox"/> Obtain IP address automatically (DHCP)	
IP Address	<input type="text" value="192.168.0.71"/> <input type="button" value="Test"/>
Subnet Mask	<input type="text" value="255.255.255.0"/>
Gateway	<input type="text" value="192.168.0.254"/>
<input checked="" type="checkbox"/> Obtain DNS from DHCP	
Primary DNS	<input type="text" value="192.168.0.254"/>
Secondary DNS	<input type="text"/>
HTTP Port	<input type="text" value="80"/> (1 - 65535) <input type="button" value="Test"/>

MAC address:

Displays the Ethernet MAC address of the device. Note that user can not change it.

Obtain IP address automatically (DHCP):

DHCP: Stands for Dynamic Host Configuration Protocol.

Enable this checked box when a DHCP server is installed on the network to issue IP address assignment. With this setting, the IP address is assigned automatically. If this device can not get an IP address within limited tries, the device will assign a default IP address, 192.168.1.100, by itself as the default IP address.

IP address, Subnet mask, and Gateway:

If you do not select **Obtain an IP address automatically**, then you need to enter these network parameters manually.

Obtain DNS from DHCP:

DNS: Stands for Domain Name System.

Enable this checked box when a DHCP server is installed on the network and provide DNS service.

Primary DNS and Secondary DNS:

If you do not select **Obtain DNS from DHCP**, then you need to enter these parameters manually.

HTTP Port:

The device supports two HTTP ports. The first one is default port 80 and this port is fixed. This port is very useful for Intranet usage. The second HTTP port is changeable. Users could assign the second port number of http protocol, and the WAN users should follow the port number to login. If the http port is not assigned as 80, users have to add the port number in back of IP address. For example: <http://192.168.1.100:8080>.

Therefore, the user can access the device by either

<http://xx.xx.xx.xx/>, or

<http://xx.xx.xx.xx:xxxx/> to access the device.

If multiple devices are installed on the LAN and also required to be accessed from the WAN, then the **HTTP Port** can be assigned as the virtual server port mapping to support multiple devices.

Click "OK" to save and enable the setting.

4.2.2 DDNS

DDNS: Stands for Dynamic Domain Name Server

Your Internet Service Provider (ISP) provides you at least one IP address which you use to connect to the Internet. The address you get may be static, meaning it never changes, or dynamic, meaning it's likely to change periodically. Just how often it changes, depends on your ISP. A dynamic IP address complicates remote access since you may not know what your current WAN IP address is when you want to access your device over the Internet. One of the possible solutions to the dynamic IP address problem comes in the form of a dynamic DNS service.

A dynamic DNS service is unique because it provides a means of updating your IP address so that your listing will remain current when your IP address changes. There are several excellent DDNS services available on the Internet. One such service you can use is www.DynDNS.org. You'll need to register with the service and set up the domain name of your choice to begin using it. Please refer to the home page of the service for detailed instructions or refer to Appendix G for more information.

If your device is connected to xDSL directly, you might need this feature. However, if your device is behind a NAT router, you will not need to enable this feature because your NAT router should take care of this job. As to xDSL environment, most of the users will use dynamic IP addresses. If users want to set up a web or a FTP server, then the Dynamic Domain Name Server is necessary.

Network **DDNS** PPPoE Streaming UPnP Bonjour IP Filter IP Notification

DDNS Disable Enable

Server Name

DDNS Host (1 ~ 30 Digits)

User Name (< 22 Digits)

Password (< 22 Digits)

OK Cancel

DDNS:

To enable or disable the DDNS service here.

Server name:

Choose the built-in DDNS server.

DDNSHost:

The domain name is applied of this device.

User name:

The user name is used to log into DDNS.

Password:

The password is used to log into DDNS.

4.2.3 PPPoE

PPPoE: Stands for Point to Point Protocol over Ethernet

A standard builds on Ethernet and Point-to-Point network protocol. It allows your device with xDSL or cable connects with broadband network directly, then your device can dial up and get a dynamic IP address. For more PPPoE and Internet configuration, please consult your dealer or ISP.

The device can directly connect to the xDSL, however, it should be setup on a LAN environment to program the PPPoE information first, and then connect to the xDSL modem. Power on again, then the device will dial on to the ISP connect to the WAN through the xDSL modem.

The procedures are

- Connect to a LAN by DHCP or Fixed IP
- Access the device; enter **Setting** → **Network** → **PPPoE** as below

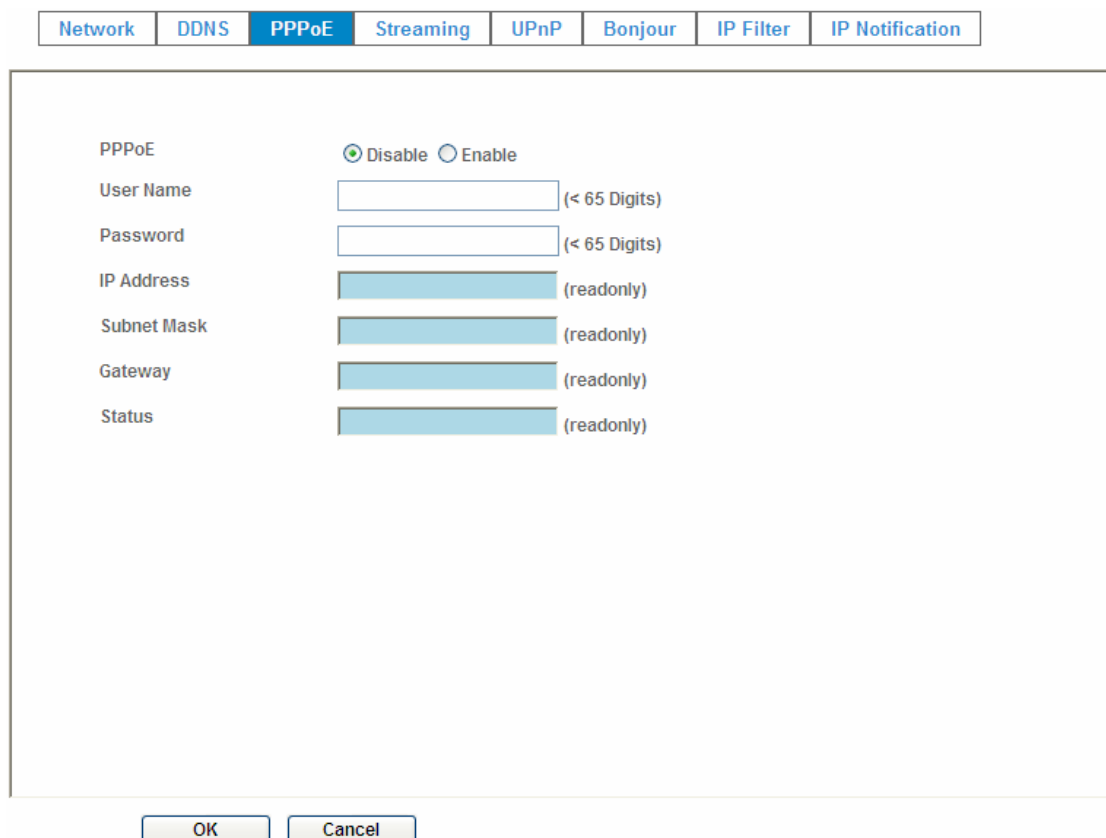

The screenshot shows the PPPoE configuration page. At the top, there is a navigation bar with tabs: Network, DDNS, PPPoE (selected), Streaming, UPnP, Bonjour, IP Filter, and IP Notification. Below the navigation bar, the PPPoE section is displayed. It includes a radio button selection for 'Disable' (selected) and 'Enable'. Below this are input fields for 'User Name' and 'Password', both with a maximum length of 65 digits. There are also read-only fields for 'IP Address', 'Subnet Mask', 'Gateway', and 'Status'.

Field	Value	Notes
PPPoE	<input checked="" type="radio"/> Disable <input type="radio"/> Enable	
User Name	<input type="text"/>	(< 65 Digits)
Password	<input type="text"/>	(< 65 Digits)
IP Address	<input type="text"/>	(readonly)
Subnet Mask	<input type="text"/>	(readonly)
Gateway	<input type="text"/>	(readonly)
Status	<input type="text"/>	(readonly)

At the bottom of the page, there are two buttons: 'OK' and 'Cancel'.

PPPoE:

To enable or disable the PPPoE service here.

User name:

Type the user name for the PPPoE service which is provided by the ISP.

Password:

Type the password for the PPPoE service which is provided by the ISP.

IP address, Subnet mask, and Gateway (read only):

Shows the IP information got from PPPoE server site.

Status:

Shows the Status of PPPoE connection.

4.2.4 Steaming

RTSP is a streaming control protocol, and a starting point for negotiating transports such as RTP, multicast and Unicast, and for negotiating codecs. RTSP can be considered a "remote control" for controlling the media stream delivered by a media server. RTSP servers typically use RTP as the protocol for the actual transport of audio/video data.

RTSP Port:

Choose the RTSP port. The RTSP protocol allows a connecting client to start a video stream. Enter the RTSP port number to use. The default value is 554.

RTP Port:

Specify the range of transmission port number of video stream. The default range is 50000 to 50999. User can specify a number between 1024 and 65535.

Network	DDNS	PPPoE	Streaming	UPnP	Bonjour	IP Filter	IP Notification
---------	------	-------	------------------	------	---------	-----------	-----------------

RTSP Port	<input type="text" value="554"/>	(554 ~ 65535)	<input type="button" value="Test"/>
RTP Port	<input type="text" value="50000"/>	~ <input type="text" value="50999"/>	(1024 ~ 65535)

<input type="button" value="OK"/>	<input type="button" value="Cancel"/>
-----------------------------------	---------------------------------------

4.2.5 UPnP

UPnP is short for Universal Plug and Play, which is a networking architecture that provides compatibility among networking equipment, software, and peripherals. This device is an UPnP enabled Network Camera. If your operating system is UPnP enabled, the device will automatically be detected and a new icon will be added to "My Network Places." If you do not want to use the UPnP functionality, it can be disabled.

In addition, this device also provides UPnP IGD function for NAT traversal easily. Use NAT traversal when your device is located on an intranet (LAN) and you wish to make it available from the other (WAN) side of a NAT router. With NAT traversal properly configured, all HTTP traffic to an external HTTP port in the NAT router will be forwarded to the device.

Network	DDNS	PPPoE	Streaming	UPnP	Bonjour	IP Filter	IP Notification
---------	------	-------	-----------	-------------	---------	-----------	-----------------

UPnP Disable Enable

Friendly Name (readonly)

UPnP NAT Traversal Disable Enable

Port Range ~ (1 ~ 65535)

External IP Address (readonly)

UPnP:

To enable or disable the UPnP service here.

Friendly Name:

Shows the friendly name of this device here.

UPnP NAT Traversal

When enabled, the device will attempt to configure port mapping in a NAT router on your network, using UPnP™. **Note** that UPnP™ must be enabled in the NAT router first.

Port Range:

The port range will open in NAT router.

External IP address:

Show the IP address and port for WAN access through Internet. If NAT traversal is configured successfully, user can use this IP address and port to access this device. The external IP address is not shown in case NAT traversal function is failed.

4.2.6 Bonjour

Bonjour, also known as zero-configuration networking, enables automatic discovery of computers, devices, and services on IP networks. Bonjour uses industry standard IP protocols to allow devices to automatically discover each other without the need to enter IP addresses or configure DNS servers. Specifically, Bonjour enables automatic IP address assignment without a DHCP server, name to address translation without a DNS server, and service discovery without a directory server. Bonjour is an open protocol which Apple has submitted to the IETF as part of the ongoing standards-creation process.

Bonjour:

To enable or disable the Bonjour service here.

Friendly Name:

Shows the friendly name of this device here.

Network	DDNS	PPPoE	Streaming	UPnP	Bonjour	IP Filter	IP Notification
---------	------	-------	-----------	------	----------------	-----------	-----------------

Bonjour	<input type="radio"/> Disable <input checked="" type="radio"/> Enable
Friendly Name	<input type="text" value="AirCam IP-200PHD-004FAEA002BB"/> (readonly)

<input type="button" value="OK"/>	<input type="button" value="Cancel"/>
-----------------------------------	---------------------------------------

4.2.7 IP Filter

You can enter different user's IP address which are allowing enter or denying by the device.

IP Filter:

To enable or disable the IP filter function here.

IP Filter Policy:

Choose the filter policy where is denying or allowing.

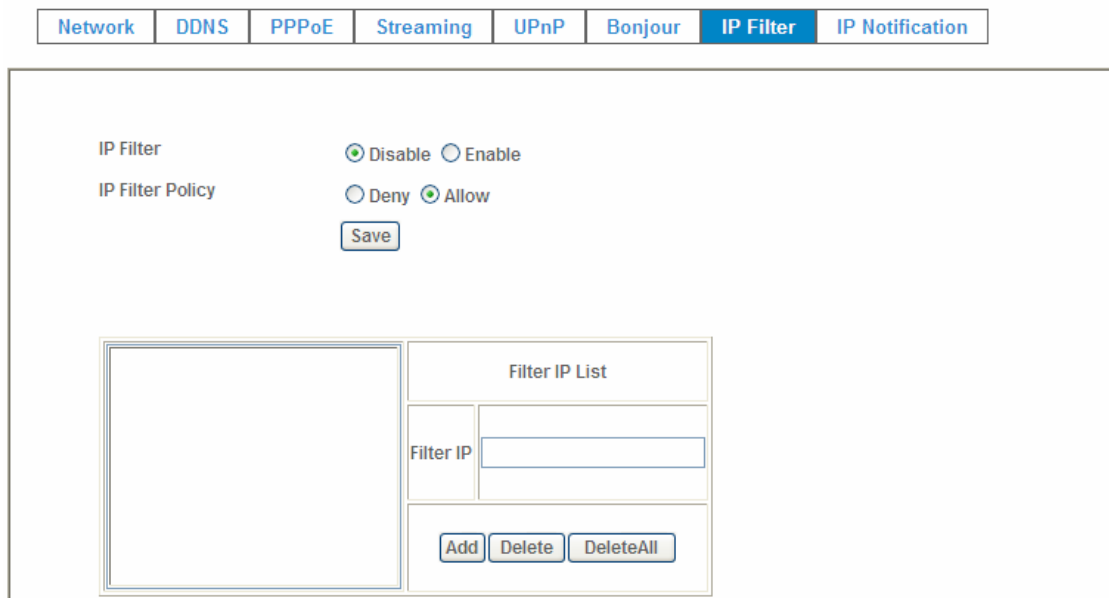

The screenshot shows the IP Filter configuration page. At the top, there is a navigation bar with tabs for Network, DDNS, PPPoE, Streaming, UPnP, Bonjour, IP Filter (selected), and IP Notification. The main content area contains the following elements:

- IP Filter:** A radio button group with Disable and Enable.
- IP Filter Policy:** A radio button group with Deny and Allow.
- Save:** A button to save the configuration.
- Filter IP List:** A table with a header "Filter IP List" and a single row with a "Filter IP" label and an empty text input field.
- Buttons:** Three buttons labeled "Add", "Delete", and "DeleteAll" are located below the table.

4.2.8 IP Notification

In case the IP address is changed, system is able to send out an email to alert someone if the function is enabled.

SMTP Notification (e-mail):

If enable this function, then the **"Send to"** and **"Subject"** fields need to be filled.

Send To:

Type the receiver's e-mail address. This address is used for reply mail.

Subject:

Type the subject/title of the E-mail.

TCP Notification:

If enable this function, then the “TCP Server“, “TCP Port“, and “Message” fields need to be filled.

TCP Server:

Type the server name or the IP address of the TCP server.

Network	DDNS	PPPoE	Streaming	UPnP	Bonjour	IP Filter	IP Notification
SMTP Notification(email) <input checked="" type="radio"/> Disable <input type="radio"/> Enable							
Send To	<input type="text"/> (< 129 Digits)						
Subject	<input type="text" value="IP notification"/> (< 65 Digits)						
TCP Notification <input checked="" type="radio"/> Disable <input type="radio"/> Enable							
TCP Server	<input type="text"/> (< 65 Digits)						
TCP Port	<input type="text"/> (1 ~ 65535)						
Message	<input type="text"/> (< 65 Digits)						
HTTP Notification <input checked="" type="radio"/> Disable <input type="radio"/> Enable							
URL	<input type="text" value="http://"/> (< 61 Digits)						
HTTP Login Name	<input type="text"/> (< 22 Digits)						
HTTP Login Password	<input type="text"/> (< 22 Digits)						
Proxy Address	<input type="text"/> (< 129 Digits)						
Proxy Port	<input type="text"/> (1 ~ 65535)						
Proxy Login Name	<input type="text"/> (< 22 Digits)						
Proxy Login Password	<input type="text"/> (< 22 Digits)						
Customer parameters	<input type="text"/> (< 65 Digits)						
Message	<input type="text"/>						
<input type="button" value="OK"/> <input type="button" value="Cancel"/>							

TCP Port:

Set port number of TCP server.

Message:

The message will be sent to FTP server.

HTTP Notification:

If enable this function, then the fields below need to be filled.

URL:

Type the server name or the IP address of the HTTP server.

HTTP Login name:

Type the user name for the HTTP server.

HTTP Login Password:

Type the password for the HTTP server.

Proxy Address:

Type the server name or the IP address of the HTTP Proxy.

Proxy Port:

Set port number of Proxy.

Proxy Login name:

Type the user name for the HTTP Proxy.

Proxy Login Password:

Type the password for the HTTP Proxy.

Custom parameter:

User can set specific parameters to HTTP server.

Message:

The message will be sent to HTTP server.

4.3 Camera – Adjust Camera Parameters

Use this menu to set the functions of the camera parameters of the device.

4.3.1 Picture

Picture
Privacy Mask

Rotation Normal

White Balance Auto

Exposure Control Auto Hold

Maximum Exposure Time 1/5 S

Color Level
 70 (0 ~ 100)

Brightness
 50 (0 ~ 100)

Contrast
 50 (0 ~ 100)

Sharpness
 50 (0 ~ 100)

De-Noise Off

Default Settings

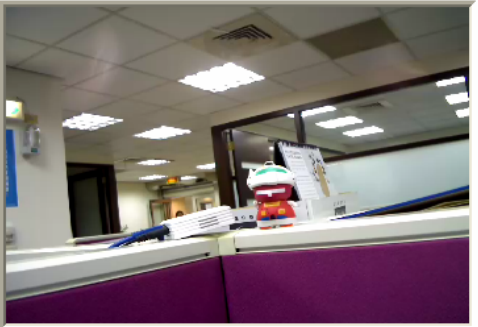

Rotation:

Turn the “Mirror” and “Vertical Flip” On or OFF. The image will be overturned as below.

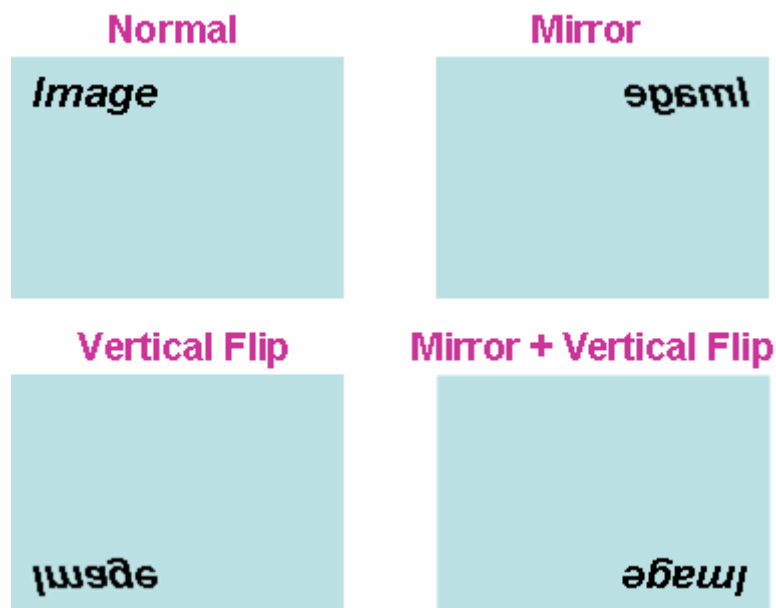

White Balance:

Auto: will adjust the white balance automatically.

Hold: will hold the white balance.

Exposure Control:

Auto: will adjust the internal gain automatically.

Hold: will hold the internal gain.

Color Level:

Large value will be colorful.

Brightness:

Large value will brighten camera.

Sharpness:

Large value will sharpen camera.

Contrast:

Large value will contrast camera heavily.

De-Noise:

De-Noise can remove or lower unwanted noise and preserve fine details and edges.

Default Settings:

Restore to factory image settings.

4.3.2 Privacy Mask

Use this page to specify privacy mask window 1 to window 7 and set the name and gray level for selected window.

Add and Delete:

To add or delete the privacy mask windows, user can specify up to 7 windows to mask the video captured by this device. By dragging mouse on the image, you can change the position and size of the selected window accordingly.

Name:

Name of the specified window.

Level

Defines the gray level of mask block. The lower value will be darker.

Picture Privacy Mask

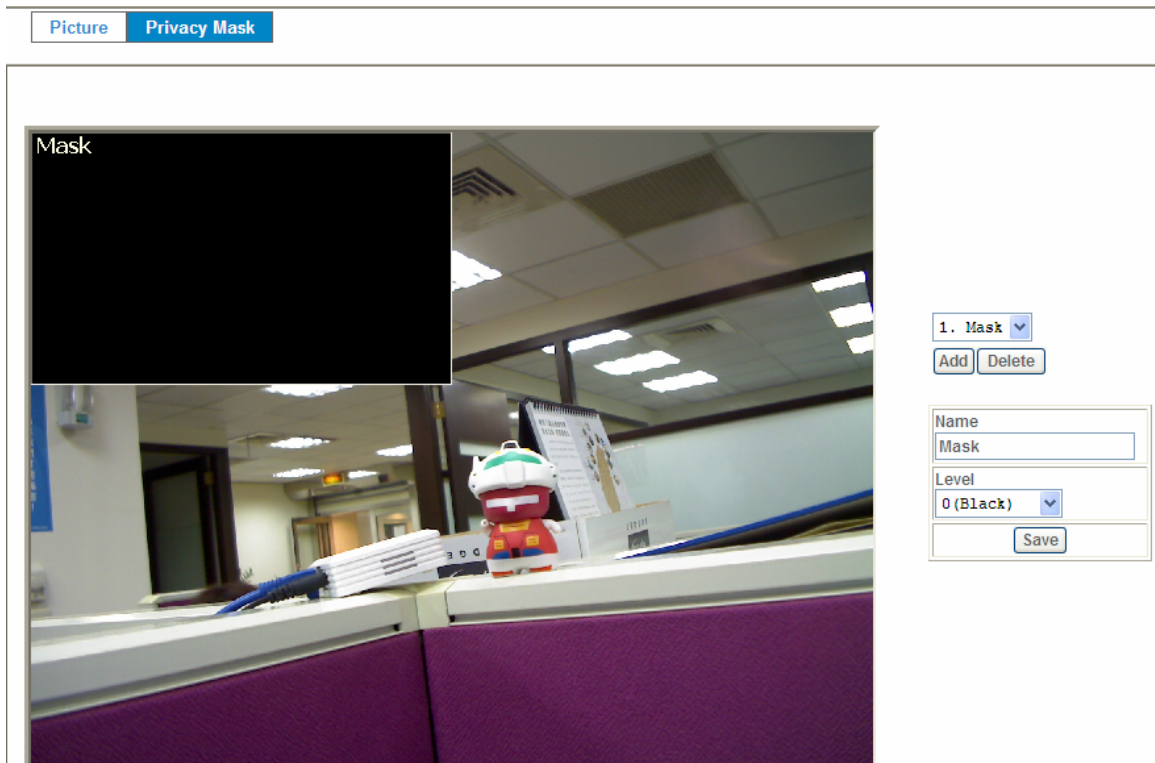

Mask

1. Mask

Add Delete

Name
Mask

Level
0 (Black)

Save

4.4 System – Configure and Maintain

Use this menu to perform the principal settings of the device.

4.4.1 System

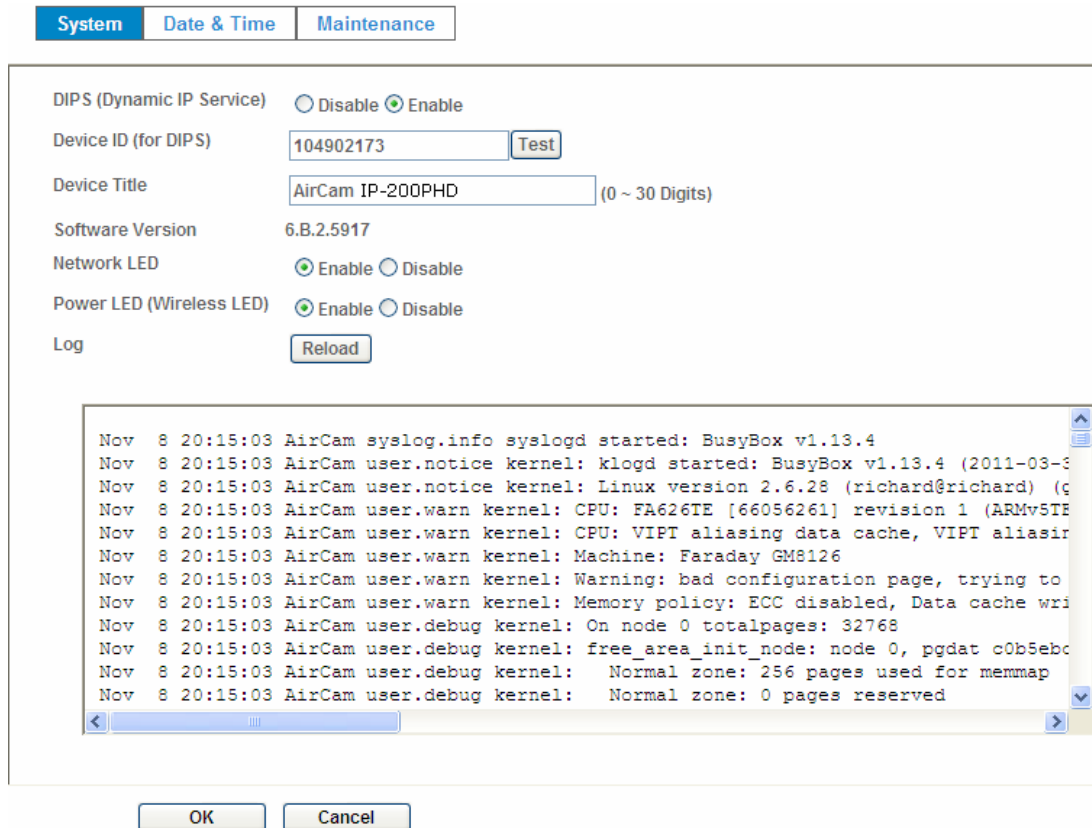

System | Date & Time | Maintenance

DIPS (Dynamic IP Service) Disable Enable

Device ID (for DIPS)

Device Title (0 ~ 30 Digits)

Software Version 6.B.2.5917

Network LED Enable Disable

Power LED (Wireless LED) Enable Disable

Log

```

Nov 8 20:15:03 AirCam syslog.info syslogd started: BusyBox v1.13.4
Nov 8 20:15:03 AirCam user.notice kernel: klogd started: BusyBox v1.13.4 (2011-03-3
Nov 8 20:15:03 AirCam user.notice kernel: Linux version 2.6.28 (richard@richard) (g
Nov 8 20:15:03 AirCam user.warn kernel: CPU: FA626TE [66056261] revision 1 (ARMv5TE
Nov 8 20:15:03 AirCam user.warn kernel: CPU: VIPT aliasing data cache, VIPT aliasir
Nov 8 20:15:03 AirCam user.warn kernel: Machine: Faraday GM8126
Nov 8 20:15:03 AirCam user.warn kernel: Warning: bad configuration page, trying to
Nov 8 20:15:03 AirCam user.warn kernel: Memory policy: ECC disabled, Data cache wri
Nov 8 20:15:03 AirCam user.debug kernel: On node 0 totalpages: 32768
Nov 8 20:15:03 AirCam user.debug kernel: free_area_init_node: node 0, pgdat c0b5ebc
Nov 8 20:15:03 AirCam user.debug kernel: Normal zone: 256 pages used for memmap
Nov 8 20:15:03 AirCam user.debug kernel: Normal zone: 0 pages reserved
  
```

DIPS (Dynamic IP Service):

To enable or disable the DIPS® (Dynamic IP Service) function.

Device ID (for DIPS):

It's a unique LED number of each device for identification and this ID is used for DIPS.

In the Appendix G, it describes how to locate your device from Internet by DDNS service. However, we provide another easier way to do the same job called Dynamic IP Service, DIPS®.

To use this service, just follow four steps below:

- (1) Enable DIPS function of the device.
- (2) Check your Device ID from this page. This is a unique number for each device.
- (3) If your device is behind a NAT router, please configure your device properly. You could refer to section "Install the Camera behind a NAT Router" above. You only need to do this job one time.
- (4) Visiting our company's web site, you can find DIPS service page as below:



Enter your Device Number and press "OK" button.

Then, a new web page will pop up and link to your device accordingly. You will see that DIPS is a much easier service than DDNS.

Device Title:

You can enter the name of this unit here. It's very useful to identify the specific device from multiple units. The information will be shown on IPWizard II once the device is found.

Software Version:

This information shows the software version of the device.

Network LED:

To turn on or off Network LED.

Power LED:

To turn on or off Power LED.

Log:

User can check the system log information of the device, including the *Main Info, Appended Info, Operator IP, and so on ...*

Reload:

Click this button; user can refresh the log information of the device.

4.4.2 Date & Time

You can setup the device or make it synchronized with PC or remote NTP server. Also, you may select your time zone in order to synchronize time locally.

Server Date & Time:

Displays the date and time of the device.

PC Time:

Displays the date and time of the connected PC.

Adjust:

- Synchronize with PC:

Click this option to enable time synchronization with PC time.

- Manual setting:

Click this option to set time and date manually.

- Synchronize with NTP:

Click this option if you want to synchronize the device's date and time with those of time server called NTP server (Network Time Protocol).

NTP Server: Type the host name or IP address or domain name of the NTP server.

NTP sync. Interval: Select an interval between 1 and 23 hours at which you want to adjust the device's time referring to NTP server

Time zone:

Set the time difference from Greenwich Mean Time in the area where the device is installed.

Daylight Saving:

Disable or enable the daylight saving adjustment.

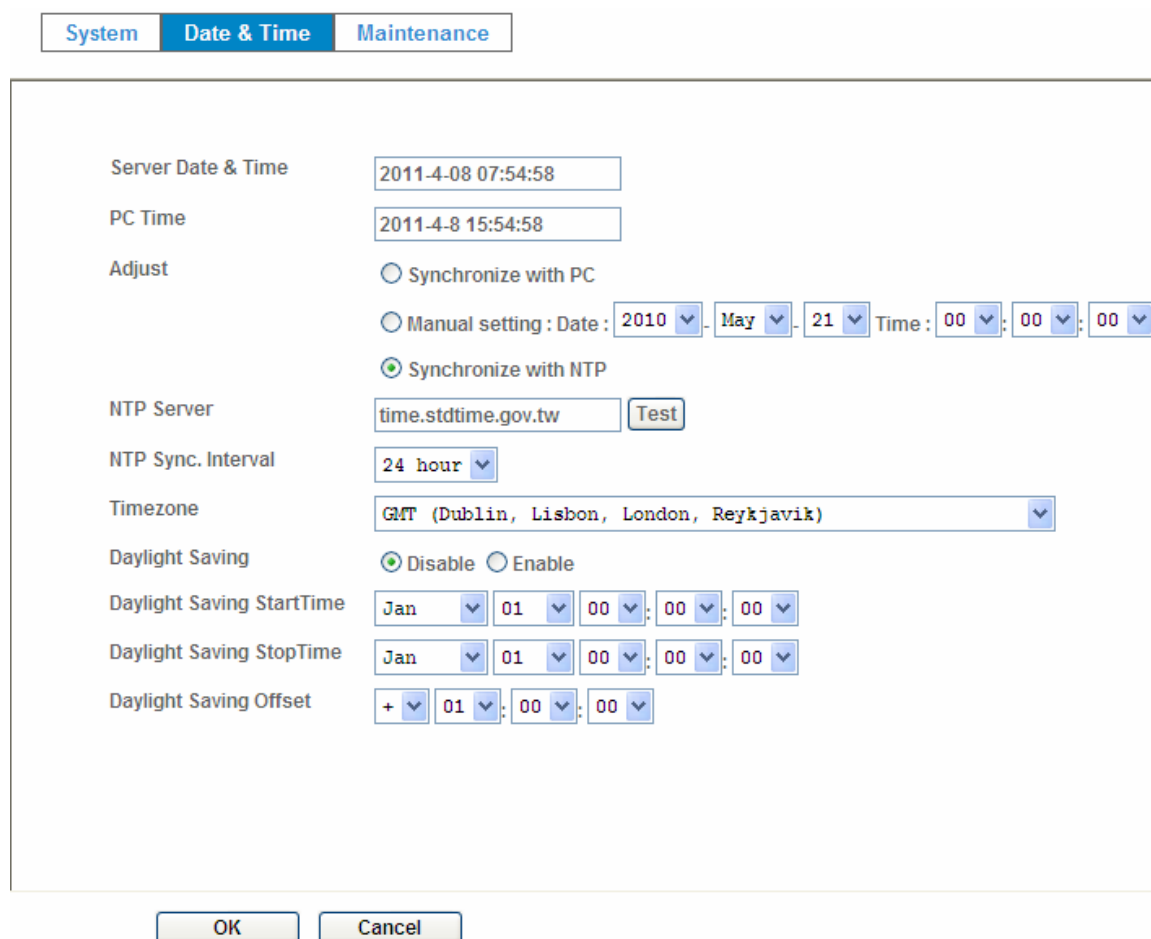

The screenshot shows the 'Date & Time' configuration page. At the top, there are three tabs: 'System', 'Date & Time' (selected), and 'Maintenance'. The main content area contains the following settings:

- Server Date & Time: 2011-4-08 07:54:58
- PC Time: 2011-4-8 15:54:58
- Adjust: Synchronize with PC, Manual setting : Date : 2010 May 21 Time : 00:00:00, Synchronize with NTP
- NTP Server: time.stdtime.gov.tw [Test]
- NTP Sync. Interval: 24 hour
- Timezone: GMT (Dublin, Lisbon, London, Reykjavik)
- Daylight Saving: Disable Enable
- Daylight Saving StartTime: Jan 01 00:00:00
- Daylight Saving StopTime: Jan 01 00:00:00
- Daylight Saving Offset: + 01:00:00

At the bottom of the page, there are 'OK' and 'Cancel' buttons.

4.4.3 Maintenance

Hard Factory Default (Include the network setting):

Recall the device hard factory default settings. Note that click this button will reset all device's parameters to the factory settings (including the IP address).

Factory Default (Except the network setting):

The unit is restarted and most current settings are reset to factory default values. This action will not reset the network setting.

Backup Setting:

To take a backup of all of the parameters, click this button. If necessary, it will then be possible to return to the previous settings, if settings are changed and there is unexpected behavior.

Restore Setting:

Click the “**Browse**” button to locate the saved backup file and then click the “**Restore Setting**” button. The settings will be restored to the previous configuration.

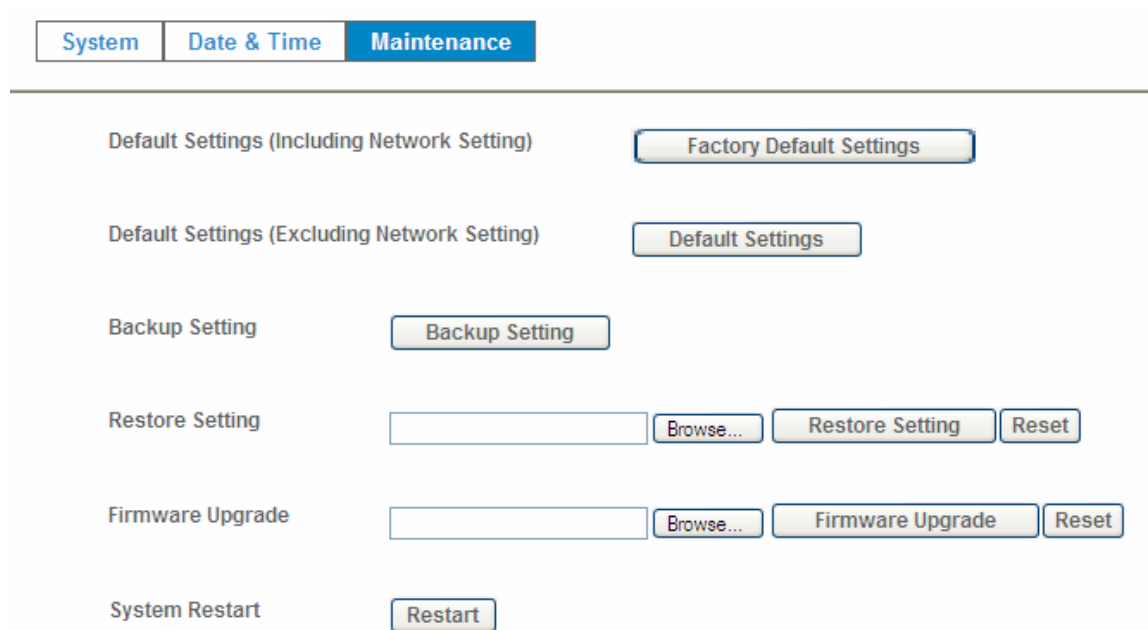

System	Date & Time	Maintenance
Default Settings (Including Network Setting)		Factory Default Settings
Default Settings (Excluding Network Setting)		Default Settings
Backup Setting	Backup Setting	
Restore Setting	<input type="text"/>	Browse... Restore Setting Reset
Firmware Upgrade	<input type="text"/>	Browse... Firmware Upgrade Reset
System Restart	Restart	

Firmware Upgrade:

The device supports new firmware upgrade (the software that controls the operation in the device). Please contact your dealer for the latest version if necessary.

Download the latest firmware file from our website or your dealer. Unzip this firmware file to binary file and store it into your PC. Then follow the steps as bellows carefully:

1. Close all other application programs which are not necessary for firmware update.
2. **Make sure that only you access this device while firmware updating.**
3. Disable Motion Detection function.

4. Click "**Browse**" button. Select the Firmware binary file.
(**Note** that it must make sure that the Firmware only applies to this device, once update, it will be burned into FLASH ROM of system.)
5. Once the firmware file was selected, click "**Firmware Upgrade**" button.
6. The upgrade progress information will be displayed. Once the uploading process completed, the device will reboot the system automatically.
7. Please wait for timer countdown, and then you can use IPWizard II to search the device again.

Warning!!! The download firmware procedure cannot be interrupted. If the power and/or network connection are broken during the download procedure, it might possibly cause serious damage to the device.

Be aware that you should not turn off the power during updating the firmware and wait for finish message.

Furthermore, the firmware upgrade procedure always is risk and do not try to upgrade new firmware if it's not necessary.

System Restart:

The device is restarted without changing any of the network settings. It means the IP address of the device will not change after firmware upgrade.

4.5 Video – Configure Profile

This device provides 2 modes of video profile. The first one is Mega-Pixel mode which supports video resolution up to Mega-pixel. However the maximum frame rate of this mode is up to 15fps only. The second one is VGA mode which supports video resolution up to VGA but frame rate can be up to 30fps. User only can select either Mega-pixel or VGA mode to operate the camera. Switching Mega-pixel and VGA, the device will take time to reboot system.

4.5.1 Common

Common
Video Profile
ROI

Text Overlay Setting

Video Profile

Include Date

Predefined YYYY-MM-DD ▼

Own %Y-%m-%d (0 ~ 12 Digits)

Include Time

Predefined 24h ▼

Own %H:%M:%S (0 ~ 12 Digits)

Include Text (0 ~ 20 Digits)

720P Mode 2 MEGA Mode

OK
Cancel

Text Overlay Setting:

There are some important information can be embedded into image, including date, time, and/or text.

Video Profile:

User can only choose either 720P or 2 Mega modes. The 720P mode can serve H.264 and JPEG streams up to 1280x720 resolution simultaneously. On the other hand, 2 Mega mode, it can streams up to 1600x1200 resolution simultaneously.

4.5.2 Video Profile

Common Video Profile ROI									
Name	Video Type	Resolution	Rate Control	Quality	Bitrate	Max Frame Rate	GOP Control	ROI	Multicast
Profile1	h264	1600x1200	VBR	90	10000	15	30	no	no
Profile2	mjpeg	1600x1200	VBR	90	10000	6	30	no	no
Profile3	h264	640x480	VBR	90	2048	15	30	no	no
Profile4	mjpeg	640x480	VBR	90	2048	6	30	no	no
Profile5	h264	320x240	VBR	90	1024	15	30	no	no
Profile6	mjpeg	320x240	VBR	90	1024	15	30	no	no
Profile7	h264	160x112	VBR	90	128	15	30	no	no
Profile8	mjpeg	160x112	VBR	90	128	15	30	no	no

Name	Profile1
Video Type	h264
Resolution	1600x1200
ROI	<input type="radio"/> Yes <input checked="" type="radio"/> No
Rate Control	VBR
Quality	90
Max Frame Rate	15
GOP Control	30
Multicast	<input type="radio"/> Enable <input checked="" type="radio"/> Disable
Multicast Video	IP Address 239.198.97.181 Port 0 (0 means auto, 1024 - 65534)
Multicast Audio	IP Address 239.198.97.181 Port 0 (0 means auto, 1024 - 65534)
Time to live	1 (1 - 255)

OK Cancel

Name:

Assign a name to the selected profile.

Video Type:

Video codec of the selected video profile.

Resolution:

Resolution of the selected video profile.

ROI:

Assign the selected profile as a ROI stream or not.

Rate Control:

Defines the rate control method of this profile. There are four options: Constant Bit Rate (CBR), Variable Bit Rate (VBR), Enhanced Constant Bit Rate (ECBR), and Enhanced Variable Bit Rate (EVBR).

For CBR, the video bit rate is between low to high bandwidth based on different resolutions. User can set the desired bit rate to match the limitation of bandwidth.

For VBR, user should choose the quality level to set the video quality rather than bit rate. The quality level is between 1 and 100. The higher value can reach the better quality but of course will consume higher bandwidth.

For ECBR, the video bitrate is based on normal CBR mode. However, the target bitrate can be increased to max target bitrate while lots of motion in video. The max target bitrate will keep a pre-defined time period and then back to normal CBR bitrate.

For EVBR, the video bitrate is based on normal VBR mode. However, the target bitrate can be increased to max target bitrate while lots of motion in video. The max target bitrate will keep a pre-defined time period and then back to normal VBR mode.

Max Frame Rate:

Defines the targeted frame rate of this profile. For example, set the frame rate to 15 fps, then the image will be updated for 15 frames per second as possible. User need to set reasonable max frame rate versus video quality under the limited bandwidth.

GOP Control:

Defines the Intra/Inter-frame (I/P) ratio of this profile. For example, set the GOP to 30, then the video stream will have one Intra-frame every 30 frames.

4.5.3 ROI

ROI means Region of Interest. Use this page to specify ROI window which ROI is QVGA resolution.

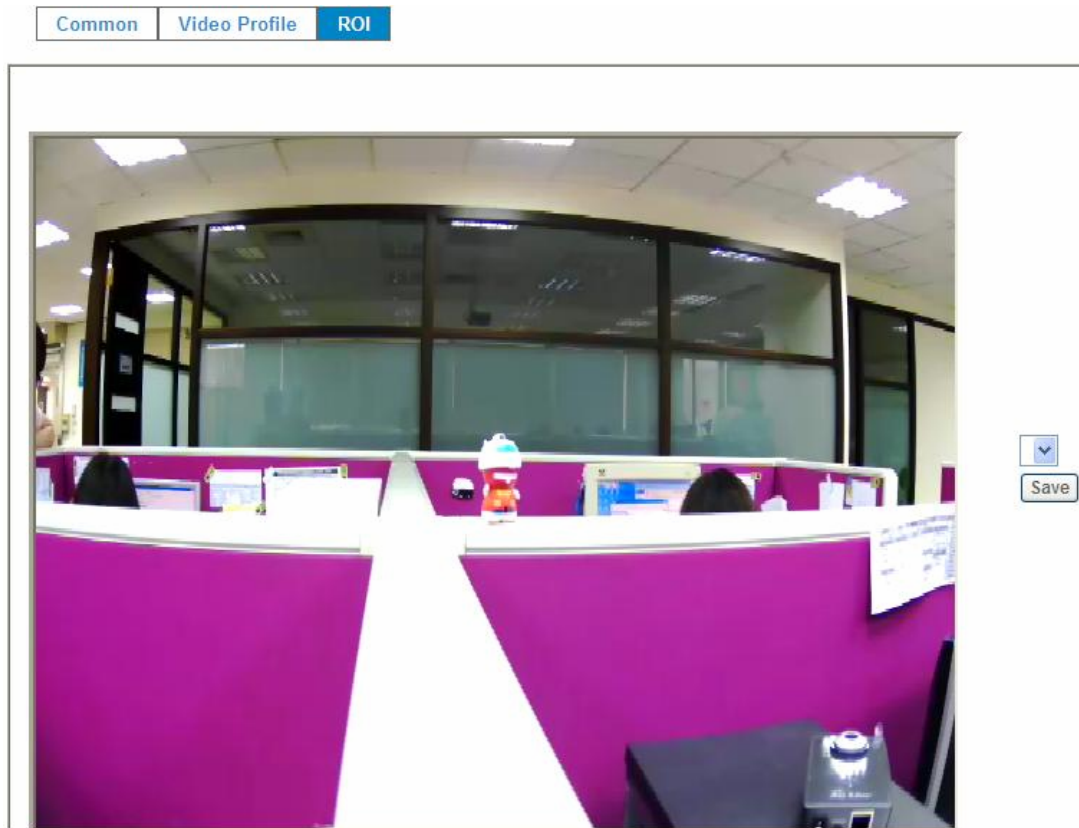

4.6 Audio – Audio Parameters

4.6.1 Setting

Setting

Audio	<input type="radio"/> Disable <input checked="" type="radio"/> Enable
Mute While PT	<input checked="" type="radio"/> Disable <input type="radio"/> Enable
Audio Mode	<input checked="" type="radio"/> Simplex <input type="radio"/> Full duplex
Input Gain	80 <input type="button" value="v"/>
Output Gain	80 <input type="button" value="v"/>

Audio:

To enable or disable audio function

Mute While PT:

Mute the audio while pan and/or tilt motion

Audio Mode:

To select Simplex or Full duplex (2-way audio) mode

Input Gain:

To adjust gain of input audio

Output Gain:

To adjust gain of output audio

4.6.2 Manage User Name, Password and Login Privilege

Use this menu to add, update, or remove the usernames and passwords of the Administrator and viewer.

Setting

Viewer Login

 Anonymous
 Only users in database
 Save

User Name	Access Right	PTZ Control
admin	administrator	yes

User Name	Access Right	PTZ Control

User Name	<input type="text"/>	(1 ~ 20 Digits)
Password	<input type="text"/>	(0 ~ 20 Digits)
Verify Password	<input type="text"/>	(0 ~ 20 Digits)
Access Right	<input type="radio"/> Administrator <input checked="" type="radio"/> Viewer	
PTZ Control	<input type="radio"/> Enable <input checked="" type="radio"/> Disable	
Add Modify Delete		

Viewer login:

Select “Anonymous” to allow any one viewing the video once connected. Otherwise, only users in database can view the video after login.

Access Right:

Administrator can access every function in this device. However, Viewers only can view the video and access limited function.

PTZ Control:

Authorize this user to control PTZ function or not.

Add, update, and remove of Users account:

Manage the user's account of viewer user.

4.6.3 E-Mail

You may setup SMTP mail parameters for further operation of Event Schedule. That's, if users want to send the alarm message out, it will need to configure parameters here and also add at least one event schedule to enable event triggering.

Setting

SMTP Server	<input type="text"/>	(< 129 Digits)	<input type="button" value="Test"/>
SMTP Port	<input type="text" value="25"/>	(1 ~ 65535)	
SSL	<input checked="" type="radio"/> Disable <input type="radio"/> Enable		
SMTP Authentication	<input checked="" type="radio"/> Disable <input type="radio"/> Enable		
Authentication User Name	<input type="text"/>	(< 65 Digits)	
Authentication Password	<input type="text"/>	(< 22 Digits)	
E-mail From	<input type="text"/>	(< 129 Digits)	
E-mail To	<input type="text"/>	(< 129 Digits)	
E-mail Subject	<input type="text"/>	(< 65 Digits)	

SMTP Server:

Type the SMTP server name or the IP address of the SMTP server.

Test:

Send a test mail to mail server to check this account is available or not.

SMTP Port:

Set port number of SMTP service.

SSL:

Enable SSL function or not.

SMTP Authentication:

Select the authentication required when you send an e-mail.

Disable: if no authentication is required when an e-mail is sent.

Enable: if authentication is required when an e-mail is sent.

Authentication User name:

Type the user name for the SMTP server if **Authentication** is **Enable**.

Authentication Password:

Type the password for the SMTP server if **Authentication** is **Enable**.

E-mail To:

Type the receiver's e-mail address.

E-mail From:

Type the sender's E-mail address. This address is used for reply e-mails.

E-mail Subject:

Type the subject/title of the e-mail.

4.6.4 Object Detection

Use this menu to specify motion detection window 1 to window 10 and set the conditions for detection while observing a captured image.

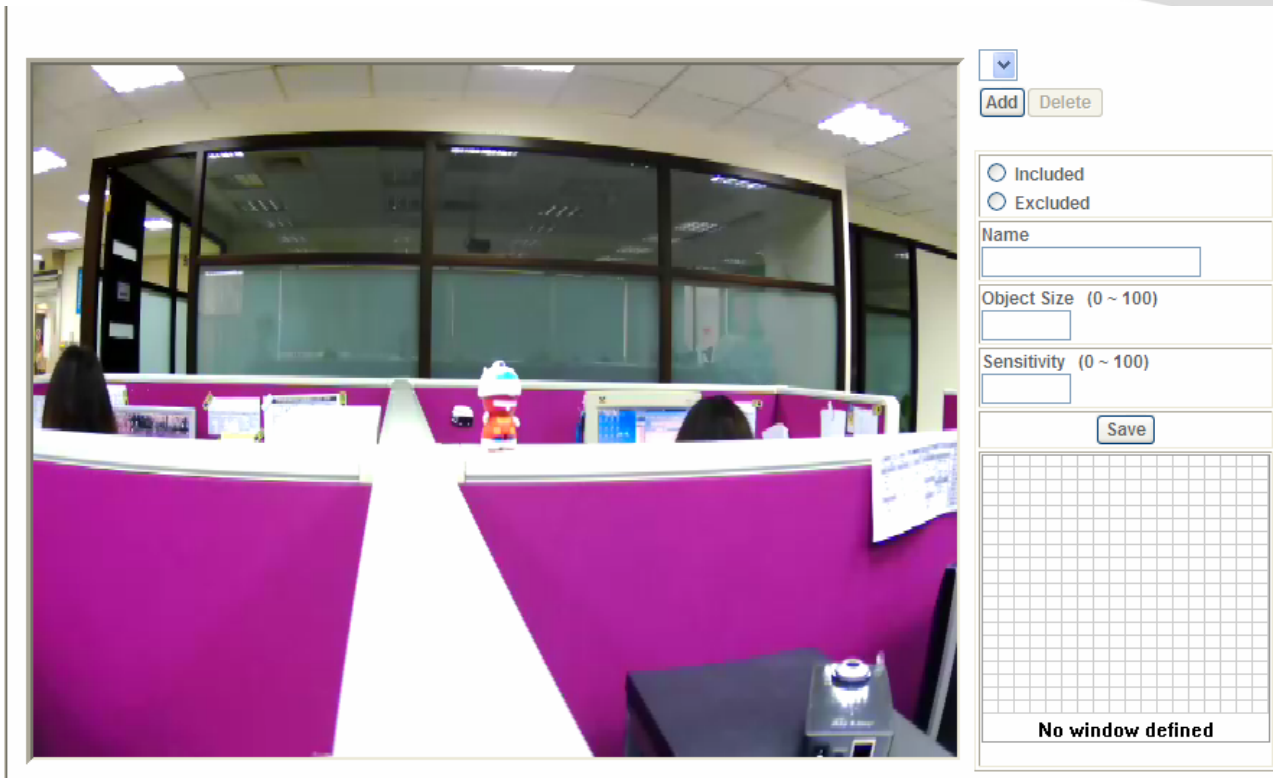
**Add and Del:**

To add or delete the motion windows. User can specify up to 10 Included and/or Excluded windows to monitor the video captured by this device. By dragging mouse on the image, you can change the position and size of the selected motion window accordingly.

Included or Excluded Window:

These windows can be specified as Included or Excluded type.

Included windows target specific areas within the whole video image

Excluded windows define areas within an Include window that should be ignored (areas outside Include windows are automatically ignored)

Name:

Name of the specified motion window.

Object Size:

Defines the object size of motion detection. The higher object size will only larger objects trigger motion detection. The lower object size will even small objects trigger motion detection too. Generally speaking, the smaller size will be easier to trigger event.

Sensitivity

Defines the sensitivity value of motion detection. The higher value will be more sensitivity.

4.6.5 Storage – Status and Configuration of SD card

This page shows the status of attached SD card. You may setup related parameters to manage the attached SD card also.

SD Card

Disk ID	<input type="text" value="SD_DISK"/>	<input type="button" value="Mount"/>	<input type="button" value="Unmount"/>	
Status	Free space	<input type="text" value="0% - 0KB"/>	<input type="button" value="Reload"/>	<input type="button" value="Format"/>
	Total size	<input type="text" value="KB"/>		
	Status	<input type="text" value="No SD card inserted"/>		
	Full	<input type="text" value="Yes"/>		
	Readonly	<input type="text" value="No"/>		
<input type="checkbox"/> Enable automatic disk cleanup				
Remove recordings older than: <input type="text" value="7"/> day(s)				
Remove oldest recordings when disk is: <input type="text" value="95"/> % full				
<input type="checkbox"/> Lock disk				

Enable automatic disk cleanup:

Delete old recorded files while the conditions are reached as below.

Remove recordings order than:

Delete old files by days.

Remove oldest recordings when disk is:

Delete old files by left capacity.

4.6.6 Recording List- Files List Inside SD Card

This page shows the files list information. User may play or delete the selected file.

Recording List

Date	File	Trigger by	Size
<input type="button" value="Reload"/>		<input type="button" value="Play"/> <input type="button" value="Remove"/>	

4.6.7 Event Sever

- **FTP Server**

You may setup FTP parameters for further operation of Event Schedule. That's, if users want to send the alarm message to an FTP server, it will need to configure parameters here and also add at least one event schedule to enable event triggering as SMTP.

FTP Server
TCP Server
HTTP Server
SAMBA Server

Name	FTP Server	FTP Port	FTP Path

Name		(< 22 Digits)
FTP Server		(< 65 Digits) Test
FTP Login Name		(< 22 Digits)
FTP Login Password		(< 22 Digits)
FTP Port	21	(1 ~ 65535)
FTP Path		(< 65 Digits)
FTP Passive Mode	<input checked="" type="radio"/> Disable <input type="radio"/> Enable	

Add
Modify
Delete

Name:

User can specify multiple FTP paths as wish. Therefore, user needs to specify a name for each FTP setting.

FTP Server:

Type the server name or the IP address of the FTP server.

Test:

Check the FTP server whether this account is available or not.

FTP Login name:

Type the user name for the FTP server.

FTP Login Password:

Type the password for the FTP server.

FTP Port:

Set port number of FTP service.

FTP Path:

Set working directory path of FTP server.

FTP Passive Mode:

Select passive or active mode connecting to FTP server.

- **TCP Server**

In addition to send video file to FTP server, the device also can send event message to specified TCP server.

FTP Server	TCP Server	HTTP Server	SAMBA Server
------------	-------------------	-------------	--------------

Name	TCP Server	TCP Port
<div style="border: 1px solid black; height: 150px;"></div>		
Name	<input type="text"/>	(< 22 Digits)
TCP Server	<input type="text"/>	(< 65 Digits) <input type="button" value="Test"/>
TCP Port	<input type="text"/>	(1 ~ 65535)

Name:

User can specify multiple TCP servers as wish. Therefore, user needs to specify a name for each TCP server setting.

TCP Server:

Type the server name or the IP address of the TCP server.

TCP Port:

Set port number of TCP server.

• **HTTP Server**

The device also can send event message to specified HTTP server.

FTP Server	TCP Server	HTTP Server	SAMBA Server
----------------------------	----------------------------	-----------------------------	------------------------------

Name	HTTP Server	Proxy Address
Name	<input type="text" value=""/>	(< 22 Digits)
URL	<input type="text" value="http://"/>	(< 129 Digits) <input type="button" value="Test"/>
HTTP Login Name	<input type="text" value=""/>	(< 22 Digits)
HTTP Login Password	<input type="text" value=""/>	(< 22 Digits)
Proxy Address	<input type="text" value=""/>	(< 129 Digits)
Proxy Login Name	<input type="text" value=""/>	(< 22 Digits)
Proxy Login Password	<input type="text" value=""/>	(< 22 Digits)
Proxy Port	<input type="text" value=""/>	(1 ~ 65535)

Name:

User can specify multiple HTTP servers as wish. Therefore, user needs to specify a name for each HTTP server setting.

URL:

Type the server name or the IP address of the HTTP server.

Test:

Check the HTTP server whether it is available or not.

HTTP Login name:

Type the user name for the HTTP server.

HTTP Login Password:

Type the password for the HTTP server.

Proxy Address:

Type the server name or the IP address of the HTTP Proxy.

Proxy Login name:

Type the user name for the HTTP Proxy.

Proxy Login Password:

Type the password for the HTTP Proxy.

Proxy Port:

Set port number of Proxy.

- **SAMBA Server**

The device also can send video stream to specified SAMBA server.

FTP Server	TCP Server	HTTP Server	SAMBA Server
----------------------------	----------------------------	-----------------------------	------------------------------

Name	SAMBA Server	SAMBA Path

Name	<input type="text"/>	(< 22 Digits)
SAMBA Server	<input type="text"/>	(< 65 Digits) <input type="button" value="Test"/>
SAMBA Login Name	<input type="text"/>	(< 22 Digits)
SAMBA Login Password	<input type="text"/>	(< 22 Digits)
SAMBA Path	<input type="text"/>	(< 65 Digits)

Name:

User can specify multiple HTTP servers as wish. Therefore, user needs to specify a name for each HTTP server setting.

SAMBA Server:

Type the server name or the IP address of the SAMBA server.

Test:

Check the SAMBA server whether this account is available or not.

SAMBA Login name:

Type the user name for the SAMBA server.

SAMBA Login Password:

Type the password for the SAMBA server.

SAMBA Path:

Set working directory path of SAMBA server.

4.6.8 Event Schedule

This menu is used to specify the schedule of Event or Schedule Trigger and activate the some actions provided by this device. Where the Schedule Trigger will be activated by user-define interval without event happened.

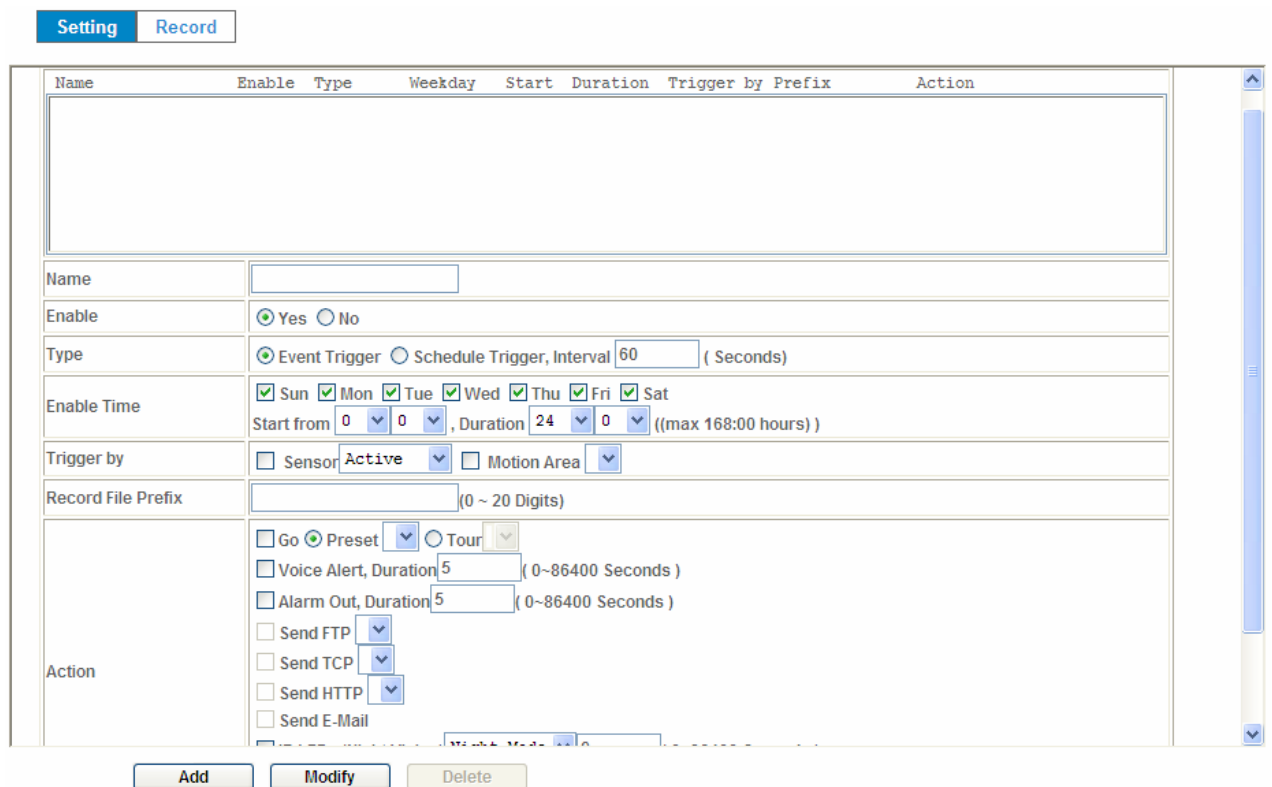

The screenshot displays the 'Event Schedule' configuration page. At the top, there are 'Setting' and 'Record' tabs. Below is a table with the following columns: Name, Enable, Type, Weekday, Start, Duration, Trigger by Prefix, and Action. The table is currently empty. Below the table, there are several configuration sections:

- Name:** A text input field.
- Enable:** Radio buttons for 'Yes' (selected) and 'No'.
- Type:** Radio buttons for 'Event Trigger' (selected) and 'Schedule Trigger, Interval' (60 seconds).
- Enable Time:** Checkboxes for days of the week (Sun-Sat, all selected). Below are 'Start from' (0:0) and 'Duration' (24:0) dropdowns.
- Trigger by:** Checkboxes for 'Sensor' (Active) and 'Motion Area'.
- Record File Prefix:** A text input field with '(0 ~ 20 Digits)'.
- Action:** A list of actions with checkboxes and dropdowns: 'Go' (selected), 'Preset', 'Tour', 'Voice Alert, Duration 5 (0~86400 Seconds)', 'Alarm Out, Duration 5 (0~86400 Seconds)', 'Send FTP', 'Send TCP', 'Send HTTP', and 'Send E-Mail'.

 At the bottom of the form are three buttons: 'Add', 'Modify', and 'Delete'.

Name:

Name of the Event or Schedule.

Enable:

Enable or disable this Event or Schedule.

Type:

Event trigger or Schedule trigger.

Enable Time:

Define the feasible time slot.

Trigger by:

Select the triggered sources.

Action:

Define the actions once event triggered.

Example 1:

Send file to FTP server by motion triggered always:

1. Select event trigger
2. Enable time: start from 00:00 to 24:00 every day
3. Trigger by: Motion Area (Added in Object Detection page)
4. Action : Send FTP (Add in Event Server -> FTP Server page)

Setting		Record
Name	<input type="text"/>	
Enable	<input checked="" type="radio"/> Yes <input type="radio"/> No	
Type	<input checked="" type="radio"/> Event Trigger <input type="radio"/> Schedule Trigger, Interval <input type="text" value="60"/> (Seconds)	
Enable Time	<input checked="" type="checkbox"/> Sun <input checked="" type="checkbox"/> Mon <input checked="" type="checkbox"/> Tue <input checked="" type="checkbox"/> Wed <input checked="" type="checkbox"/> Thu <input checked="" type="checkbox"/> Fri <input checked="" type="checkbox"/> Sat Start from <input type="text" value="0"/> : <input type="text" value="0"/> , Duration <input type="text" value="24"/> : <input type="text" value="0"/> ((max 168:00 hours)	
Trigger by	<input type="checkbox"/> Sensor <input type="text" value="Active"/> <input type="checkbox"/> Motion Area <input type="text" value=""/>	
Record File Prefix	<input type="text"/> (0 ~ 20 Digits)	
Action	<input type="checkbox"/> Go <input checked="" type="radio"/> Preset <input type="radio"/> Tour <input type="checkbox"/> Voice Alert, Duration <input type="text" value="5"/> (0~86400 Seconds) <input type="checkbox"/> Alarm Out, Duration <input type="text" value="5"/> (0~86400 Seconds) <input checked="" type="checkbox"/> Send FTP <input type="text" value="airftp"/> <input type="checkbox"/> Send TCP <input type="checkbox"/> Send HTTP <input type="checkbox"/> Send E-Mail <input type="checkbox"/> IR LEDs (Night Vision) <input type="text" value="Night Mode"/> : <input type="text" value="0"/> (0~86400 Seconds) <input type="checkbox"/> Send SD <input type="checkbox"/> Send Samba	
<input type="button" value="Add"/> <input type="button" value="Modify"/> <input type="button" value="Delete"/>		

Example 2:

Send file to E-Mail server by motion triggered from Friday 18:00 to Saturday 06:00

1. Select event trigger.
2. Enable time: start from Friday 18:00 and keep work in 12 hours, so it will stop on Saturday 06:00.
3. Trigger by : Motion Area (Added in Object Detection page)
4. Action : Send e-mail (Add in E-Mail page)
 - i. To email address: You need to input the receiver email address.
 - ii. Subject: You could specify the email subject.
 - iii. Message: You could specify the email content.

Setting		Record
Name	sent to mail	
Enable	<input checked="" type="radio"/> Yes <input type="radio"/> No	
Type	<input checked="" type="radio"/> Event Trigger <input type="radio"/> Schedule Trigger, Interval <input type="text" value="60"/> (Seconds)	
Enable Time	<input checked="" type="checkbox"/> Sun <input checked="" type="checkbox"/> Mon <input checked="" type="checkbox"/> Tue <input checked="" type="checkbox"/> Wed <input checked="" type="checkbox"/> Thu <input checked="" type="checkbox"/> Fri <input checked="" type="checkbox"/> Sat Start from <input type="text" value="0"/> <input type="text" value="0"/> , Duration <input type="text" value="24"/> <input type="text" value="0"/> ((max 168:00 hours))	
Trigger by	<input type="checkbox"/> Sensor <input type="text" value="Active"/> <input type="checkbox"/> Motion Area <input type="text" value=""/>	
Record File Prefix	<input type="text"/> (0 ~ 20 Digits)	
Action	<input type="checkbox"/> Go <input checked="" type="radio"/> Preset <input type="text" value=""/> <input type="radio"/> Tour <input type="text" value=""/> <input type="checkbox"/> Voice Alert, Duration <input type="text" value="5"/> (0~86400 Seconds) <input type="checkbox"/> Alarm Out, Duration <input type="text" value="5"/> (0~86400 Seconds) <input type="checkbox"/> Send FTP <input type="text" value="airftp"/> <input type="checkbox"/> Send TCP <input type="text" value=""/> <input type="checkbox"/> Send HTTP <input type="text" value=""/> <input checked="" type="checkbox"/> Send E-Mail To email address <input type="text" value="wayne.wu@airlive.com"/> Subject <input type="text" value="Event"/> Message <input type="text" value="WN02600HD"/> <input checked="" type="checkbox"/> Attached file <input type="checkbox"/> IR LEDs (Night Vision) <input type="text" value="Night Mode"/> <input type="text" value="0"/> (0~86400 Seconds)	
<input type="button" value="Add"/> <input type="button" value="Modify"/> <input type="button" value="Delete"/>		

Example 3:

Enable Voice Alert every 10-minute during 18:00 to 24:00 from Monday to Friday.

1. Type: Select schedule trigger and interval is 10-minute.
2. Enable time: Select Monday to Friday, and set start time from 18:00 and keep work in 6 hours.
3. Trigger by : You do not need to choose it, because this will be triggered every minute
4. Action : Voice Alert

Name	trigger_voice_alert
Enable	<input checked="" type="radio"/> Yes <input type="radio"/> No
Type	<input checked="" type="radio"/> Event Trigger <input type="radio"/> Schedule Trigger, Interval <input type="text" value="60"/> (Seconds)
Enable Time	<input checked="" type="checkbox"/> Sun <input checked="" type="checkbox"/> Mon <input checked="" type="checkbox"/> Tue <input checked="" type="checkbox"/> Wed <input checked="" type="checkbox"/> Thu <input checked="" type="checkbox"/> Fri <input checked="" type="checkbox"/> Sat Start from <input type="text" value="0"/> : <input type="text" value="0"/> , Duration <input type="text" value="24"/> : <input type="text" value="0"/> ((max 168:00 hours)
Trigger by	<input type="checkbox"/> Motion Area <input type="text" value=""/>
Record File Prefix	<input type="text" value=""/> (0 ~ 20 Digits)
Action	<input checked="" type="checkbox"/> Voice Alert, Duration <input type="text" value="5"/> (0~86400 Seconds) <input type="checkbox"/> Send FTP <input type="text" value=""/> <input type="checkbox"/> Send TCP <input type="text" value=""/> <input type="checkbox"/> Send HTTP <input type="text" value=""/> <input type="checkbox"/> Send E-Mail <input checked="" type="checkbox"/> Send SD <input type="checkbox"/> Send Samba <input type="text" value=""/>
<input type="button" value="Add"/> <input type="button" value="Modify"/> <input type="button" value="Delete"/>	

- **Record**

User can choose the type of record file for event or schedule application.

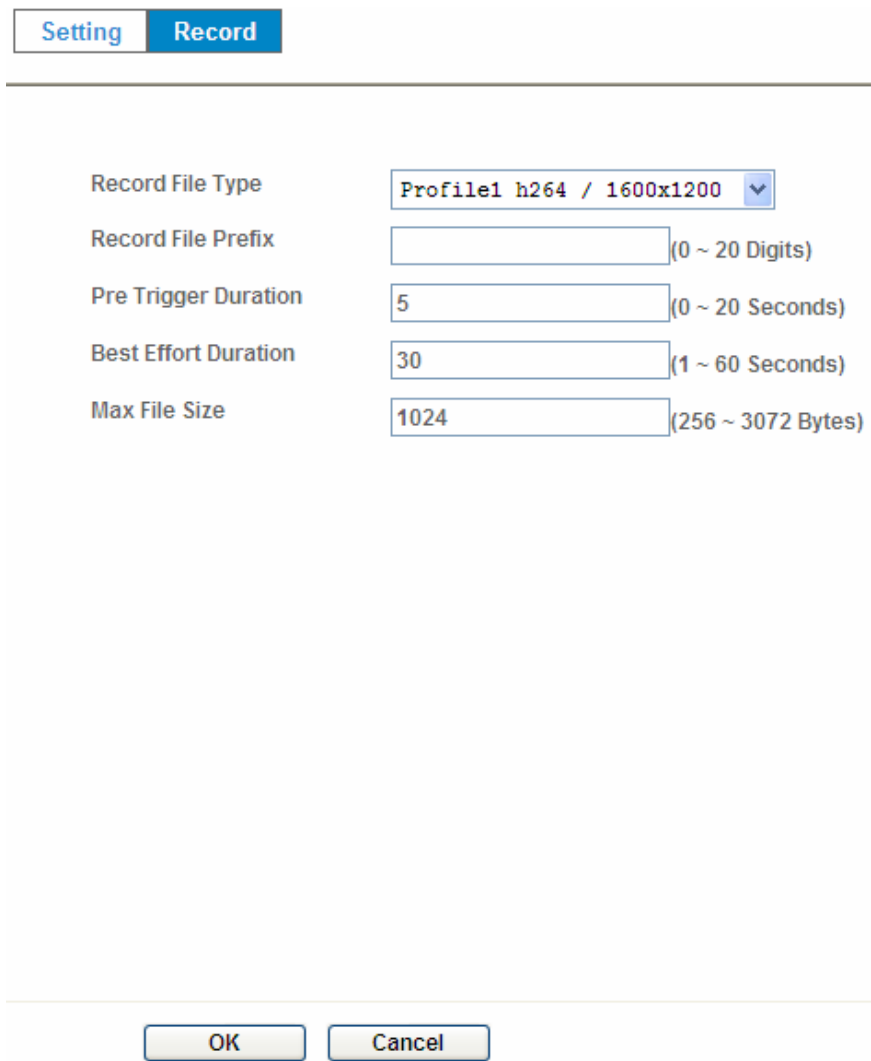

The screenshot shows a dialog box with two tabs: 'Setting' and 'Record'. The 'Record' tab is active. Below the tabs, there are five rows of settings, each with a label and a corresponding input field or dropdown menu. The settings are: 'Record File Type' with a dropdown menu showing 'Profile1 h264 / 1600x1200'; 'Record File Prefix' with an empty text box and '(0 ~ 20 Digits)' to its right; 'Pre Trigger Duration' with a text box containing '5' and '(0 ~ 20 Seconds)' to its right; 'Best Effort Duration' with a text box containing '30' and '(1 ~ 60 Seconds)' to its right; and 'Max File Size' with a text box containing '1024' and '(256 ~ 3072 Bytes)' to its right. At the bottom of the dialog box, there are two buttons: 'OK' and 'Cancel'.

Record File Type:

Choose JPEG, AVI-JPEG, or AVI-H.264 file format.

Record File Prefix:

Define the prefix of recorded filename.

JPEG Picture Numbers:

Define the picture numbers of JPEG to be sent out.

Pre-Trigger Duration:

Define the maximum duration of pre-alarm.



Post-Trigger Duration:

Define the maximum duration of post-alarm.

Max File Size:

Define the maximum buffer size of record file.

5

Troubleshooting & FAQ

5.1 Monitor the Image Section

Question	Answer or Resolution
Features	
The video and audio codec is adopted in the device.	The device utilizes H.264, MPEG4 and JPEG triple compression to providing high quality images. Where H.264 and MPEG4 are standards for video compression and JPEG is a standard for image compression. The audio codec is defined as AMR for 3GPP and G.711/G.726 for RTSP streaming.
The maximum number of users access the device simultaneously.	The maximum number of users is limited to 20. However, it also depends on the total bandwidth accessed to this device from clients. The maximum data throughput of the device is around 20~25Mbps for UDP mode and 10Mbps for HTTP mode. Therefore, the actual number of connected clients is varying by streaming mode, settings of resolution, codec type, frame rate and bandwidth. Obviously, the performance of the each connected client will slow down when many users are logged on.
The device can be used outdoors or not.	The device is not weatherproof. It needs to be equipped with a weatherproof case for outdoors using. However, equipped with a weatherproof case might disable the audio function of the device.
Install this device	
Status LED does not light up.	<ul style="list-style-type: none"> • Check and confirm that the DC power adaptor, included in packaged, is used. Secure the power connector and re-power it on again. • If the problem is not solved, the device might be faulty. Contact your dealer for further help.
The network cabling is required for the device.	The device uses Category 5 UTP cable allowing 10 and/or 100 Base-T networking.

The device will be installed and work if a firewall exists on the network.	If a firewall exists on the network, port 80 is open for ordinary data communication. The HTTP port and RTSP port need to be opened on the firewall or NAT router.
The username and password for the first time or after factory default reset	Username = admin and password = airlive . Note that it's all case sensitivity.
Forgot the username and password	Follow the steps below. 1. Restore the factory default setting by press pressing and holding down more than 3 seconds on the device. 2. Reconfigure the device.
Forgot the IP address of the device.	Check IP address of device by using the IPWizard II program or by UPnP discovery.
IPWizard II program cannot find the device.	<ul style="list-style-type: none"> • Re-power the device if cannot find the unit within 1 minutes. • Do not connect device over a router. IPWizard II program cannot detect device over a router. • If IP address is not assigned to the PC which running IPWizard II program, then IPWizard II program cannot find device. Make sure that IP address is assigned to the PC properly. • Antivirus software on the PC might interfere with the setup program. Disable the firewall of the antivirus software during setting up this device. • Check the firewall setting of your PC or Notebook.
Internet Explorer does not seem to work well with the device	Make sure that your Internet Explorer is version 6.0 or later. If you are experiencing problems, try upgrading to the latest version of Microsoft's Internet Explorer from the Microsoft webpage.
IPWizard II program fails to save the network parameters.	<ul style="list-style-type: none"> • Network may have trouble. Confirm the parameters and connections of the device.
UPnP NAT Traversal	
Can not work with NAT router	<ul style="list-style-type: none"> • Maybe NAT router does not support UPnP function. Please check user's manual of router and turn on UPnP function.

	<ul style="list-style-type: none"> • Maybe UPnP function of NAT router is not compatible to the IP camera. Please contact your dealer to get the approval routers list.
<p>Some IP cameras are working but others are failed</p>	<ul style="list-style-type: none"> • Maybe too many IP cameras have been installed on the LAN, and then NAT router is out of resource to support more cameras. You could turn off and on NAT router to clear out of date information inside router.
<p>Access this device</p>	
<p>Cannot access the login page and other web pages of the Network Camera from Internet Explorer</p>	<ul style="list-style-type: none"> • Maybe the IP Address of the Network Camera is already being used by another device or computer. To confirm this possible problem, disconnect the Network Camera from the network first, and then run the PING utility to check it out. • Maybe due to the network cable. Try correcting your network cable and configuration. Test the network interface by connecting a local computer to the Network Camera via a crossover cable. • Make sure the Internet connection and setting is ok. • Make sure enter the IP address of Internet Explorer is correct. If the Network Camera has a dynamic address, it may have changed since you last checked it. • Network congestion may prevent the web page appearing quickly. Wait for a while. <p>The IP address and Subnet Mask of the PC and Network Camera must be in the same class of the private IP address on the LAN.</p> <ul style="list-style-type: none"> • Make sure the http port used by the Network Camera, default=80, is forward to the Network Camera's private IP address. • The port number assigned in your Network Camera might not be available via Internet. Check your ISP for available port. • The proxy server may prevent you from connecting directly to the Network Camera, set up not to use the proxy server. • Confirm that Default Gateway address is correct. • The router needs Port Forwarding feature. Refer to your router's manual for details.

	<ul style="list-style-type: none"> • Packet Filtering of the router may prohibit access from an external network. Refer to your router's manual for details. • Access the Network Camera from the Internet with the global IP address of the router and port number of Network Camera. • Some routers reject the global IP address to access the Network Camera on the same LAN. Access with the private IP address and correct port number of Network Camera. • When you use DDNS, you need to set Default Gateway and DNS server address. • If it's not working after above procedure, reset Network Camera to default setting and installed it again. • If the problem is not solved, the Network Camera might be faulty. Contact your dealer for further help.
<p>Image or video does not appear in the main page.</p>	<ul style="list-style-type: none"> • The first time the PC connects to Network Camera, a pop-up Security Warning window will appear to download ActiveX Controls. When using Windows XP, or Vista, log on with an appropriate account that is authorized to install applications. • Network congestion may prevent the Image screen from appearing quickly. You may choose lower resolution to reduce the required bandwidth.
<p>Check the device's ActiveX is installed on your computer</p>	<p>Go to C:\Windows\Downloaded Program Files and check to see if there is an entry for the file "IPCamera Control". The status column should show "Installed". If the file is not listed, make sure your Security Settings in Internet Explorer are configured properly and then try reloading the device's home page. Most likely, the ActiveX control did not download and install correctly. Check your Internet Explorer security settings and then close and restart Internet Explorer. Try to browse and log in again.</p>
<p>Internet Explorer displays the following message: "Your current security</p>	<p>Setup the IE security settings or configure the individual settings to allow downloading and scripting of ActiveX controls.</p>

settings prohibit downloading ActiveX controls”.	
The device work locally but not externally.	<ul style="list-style-type: none"> • Might be caused from the firewall protection. Check the Internet firewall with your system or network administrator. The firewall may need to have some settings changed in order for the device to be accessible outside your LAN. • Make sure that the device isn't conflicting with any other web server running on your LAN. • Check the configuration of the router settings allow the device to be accessed outside your local LAN. • Check the bandwidth of Internet connection. If the Internet bandwidth is lower than target bit rate, the video streaming will not work correctly.
The unreadable characters are displayed.	Use the operating system of the selected language. Set the Encoding or the Character Set of the selected language on the Internet Explorer.
Frame rate is slower than the setting.	<ul style="list-style-type: none"> • The traffic of the network and the object of the image affect the frame rate. The network congestion causes frame rate slower than the setting. • Check the bandwidth of Internet connection. If the Internet bandwidth is lower than target bit rate, the video streaming will not work correctly. • Ethernet switching hub can smooth the frame rate.
Blank screen or very slow video when audio is enabled.	<ul style="list-style-type: none"> • Your connection to the device does not have enough bandwidth to support a higher frame rate for the streamed image size. Try reducing the video streaming size to 160x120 or 320x240 and/or disabling audio. • Audio will consume 32 kbps. Disable audio to improve video. Your Internet connection may not have enough bandwidth to support streaming audio from the device.
Image Transfer on e-mail or FTP does not work.	<ul style="list-style-type: none"> • Default Gateway and DNS server address should be set up correctly. • If FTP does not work properly, ask your ISP or network administrator about the transferring mode of FTP server.

<p>Pan/Tilt does not work. (including Click to Center and Preset Positioning)</p>	<ul style="list-style-type: none"> • Click [Refresh] on the Internet Explorer when the communication stops with the device. The image will refresh. • Other clients may be operating Pan/Tilt. • Pan/Tilt operation has reached the end of corner.
<p>Pan/Tilt does not work smoothly.</p>	<p>There may be a slight delay when you are using the Pan/Tilt feature in conjunction with streaming audio and video. If you find that there is a significant delay while panning or tilting the camera, try disabling the audio streaming and/or reducing the video streaming size.</p>
<p>Video quality of the device</p>	
<p>The focus on the Camera is bad.</p>	<ul style="list-style-type: none"> • The lens is dirty or dust is attached. Fingerprints, dust, stain, etc. on the lens can degrade the image quality.
<p>The color of the image is poor or strange.</p>	<ul style="list-style-type: none"> • Adjust White Balance. • To insure the images you are viewing are the best they can be, set the Display property setting (color quality) to 16bit at least and 24 bit or higher if possible within your computer. • The configuration on the device image display is incorrect. You need to adjust the image related parameters such as brightness, contrast, hue and sharpness properly.
<p>Image flickers.</p>	<ul style="list-style-type: none"> • Wrong power line frequency makes images flicker. Make sure the 50 or 60Hz format of your device. • If the object is dark, the image will flicker. Make the condition around the Camera brighter.
<p>Noisy images occur.</p>	<p>The video images might be noisy if the device is located in a very low light environment. Make the condition around the camera brighter or turn the White-light LED on.</p>
<p>Miscellaneous</p>	
<p>Cannot play the recorded ASF file</p>	<p>Have installed Microsoft®'s DirectX 9.0 or later and use the Windows Media Player 11.0 or later to play the AVI filed recorded by the Device.</p>

5.2 PING

The PING (stands for Packet Internet Groper) command is used to detect whether a specific IP address is accessible by sending a packet to the specific address and waiting for a reply. It's also a very useful tool to confirm the device installed or if the IP address conflicts with any other devices over the network.

If you want to make sure the IP address of the device, utilize the PING command as follows:

- Start a DOS window.
- Type ping x.x.x.x, where x.x.x.x is the IP address of the device.

The replies, as illustrated below, will provide an explanation to the problem.

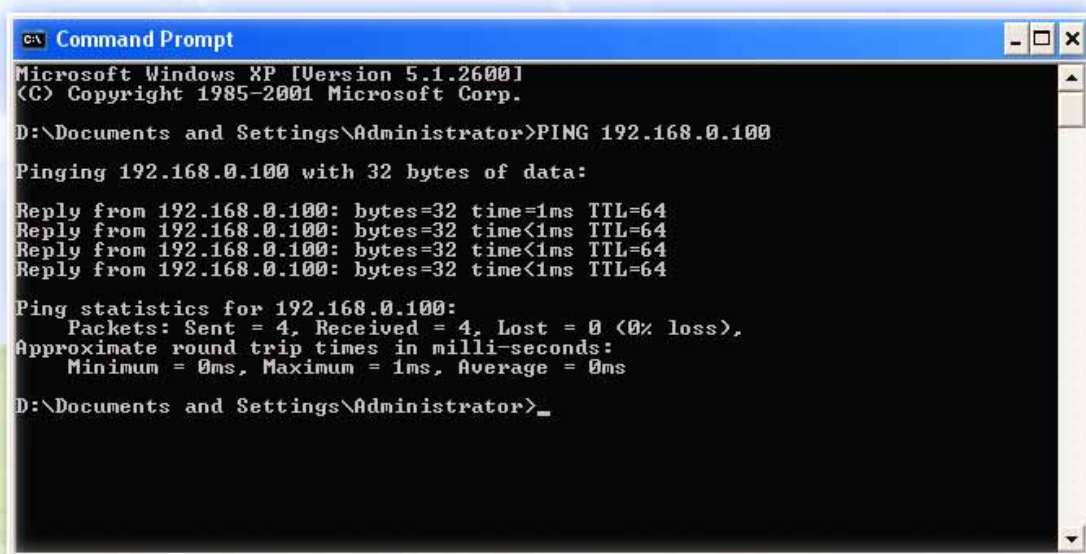

```
Microsoft Windows XP [Version 5.1.2600]
(C) Copyright 1985-2001 Microsoft Corp.

D:\Documents and Settings\Administrator>PING 192.168.0.100

Pinging 192.168.0.100 with 32 bytes of data:

Reply from 192.168.0.100: bytes=32 time=1ms TTL=64
Reply from 192.168.0.100: bytes=32 time<1ms TTL=64
Reply from 192.168.0.100: bytes=32 time<1ms TTL=64
Reply from 192.168.0.100: bytes=32 time<1ms TTL=64

Ping statistics for 192.168.0.100:
    Packets: Sent = 4, Received = 4, Lost = 0 (0% loss),
    Approximate round trip times in milli-seconds:
        Minimum = 0ms, Maximum = 1ms, Average = 0ms

D:\Documents and Settings\Administrator>_
```

If you want to detect any other devices conflicts with the IP address of Network Camera, also can utilize the PING command but you must disconnect the device from the network first.

5.3 Bandwidth Estimation

The frame rate of video transmitted from the device depends on connection bandwidth between client and server, video resolution, codec type, and quality setting of server. Here is a guideline to help you roughly estimate the bandwidth requirements from your device.

The required bandwidth depends on content of video source. The slow motion video will produce smaller bit rate generally and fast motion will produce higher bit rate vice versa. Actual results generated by the device may be varying.

Image Resolution	Average range of data sizes for JPEG mode	Average bit rate for MPEG4 mode	Average bit rate for H.264 mode
160 x 120 (QQVGA)	3 ~ 6k byte per frame	64kbps~256kbps @ 30fps	32kbps~192kbps @ 30fps
320 x 240 (QVGA)	8 ~ 20k byte per frame	NA	192kbps~512kbps @ 30fps
640 x 480 (VGA)	20 ~ 50K byte per frame	NA	384kbps~1536kbps @ 30fps
1280x720 (HD)	100 ~ 200k byte per frame	NA	512kbps~3076kbps @ 15fps
1600x1200 (UXGA)		NA	512kbps~3076kbps @ 15fps

Note: Audio streaming also takes bandwidth around 32kbps. Some xDSL/Cable modem upload speeds could not even reach up to 128 kbps. Thus, you may not be able to receive good quality video while also streaming audio on a 128 kbps or lower connection. Even though the upload speed is more than 128kbps, for optimal video performance, disabling audio streaming will get better video performance.

5.4 Specification Table

Camera		IP-200PHD	
Image Device	2 Mega-pixel image sensor		
Effective Pixels	1600 x 1200 pixels		
Sensitivity	1.0V/lux-sec		
Signal to Noise	42.3dB		
Lens	4.3mm		
IP Module			
Video			
Video Encoder	H.264, MPEG4 and Motion JPEG simultaneously (Tri-encoders)		
Video Profile	9 profiles simultaneously		
Frame Rate	Up to 30fps @ 1280x720 mode (HD mode) Up to 15fps @ 1600x1200 mode (2 Mega-pixel mode)		
Image Setting	AE, AWB Noise reduction Color, brightness, sharpness, contrast Mirror/Flip Privacy Masks Text, time and date overlay		
Streaming	Simultaneously multi-profile streaming Streaming over UDP, TCP, or HTTP M-JPEG streaming over HTTP (server push) Supports 3GPP mobile surveillance (MPEG4) Controllable frame rate and bandwidth Constant and variable bit rate (H.264) ROI		
Audio			
Audio Encoder	RTSP: G.711 64kbps, G.726 32kbps 3GPP: AMR		
Audio Streaming	One-way or two-way		
Microphone	Built-in microphone		
Audio Output	Adjustable audio output gain		
Network			
Supported Protocols	IPv4, TCP, UDP, HTTP, HTTPS, SMTP, FTP, NTP, DNS, DDNS, DHCP, DIPS, ARP, Bonjour, UPnP, RTSP,		

	RTP, RTCP, IGMP, PPPoE, 3GPP, Samba, ICMP
Security	Password protection, IP address filtering, HTTPS encrypted data transmission, user access log
Users	20 simultaneous unicast users
Ethernet	10/100M auto negotiation
System Integration	
Application Programming Interface	ONVIF Open API for software integration SDK
Alarm Triggers	Intelligent video motion detection
Motion Detection	10-zone video motion detection with included or excluded options
Alarm Events	File upload via FTP or email Notification via email, HTTP, and TCP Audio alerting output
Video Buffer	Pre- and post- alarm buffering
General	
RAM	128MB
ROM	16MB
Power Supply	12V DC external power adapter
Power Consumption	2W
Connectors	RJ-45 10BaseT/100BaseTX DC power jack Audio out Factory default reset SD card
Indication LED	Green and orange LEDs
Operating Temperature	0°C to 40°C (32°F to 104°F)
Operating Humidity	20% ~ 80% (non-condensing)
Dimension	HxWxD:74.5 x 52.6 x 35..0 (mm)
Viewing System	
OS	Windows® XP, Vista, 7
Browser	IE 6.0 or later, Firefox 2.0 or later, Safari

Cell Phone	With 3GPP player
Video Player	VLC, Quick Time, Real Player, Core Player
Software	
Search & Installation	IPWizard II
Bundled NVR Program	SecuGuard 64CH

5.5 Configure Port Forwarding Manually

The device can be used with a router. If the device wants to be accessed from the WAN, its IP address needs to be setup as fixed IP address, also the port forwarding or Virtual Server function of router needs to be setup. This device supports UPnP traversal function. Therefore, user could use this feature to configure port forwarding of NAT router first. However, if user needs to configure port forwarding manually, please follow the steps as below:

Manually installing the device with a router on your network is an easy 3–step procedure as following:

- (1) Assign a local/fixed IP address to your device
- (2) Access the Router with Your Web browser
- (3) Open/Configure Virtual Server Ports of Your Router

(1) Assign a local/fixed IP address to your device

The device must be assigned a local and fixed IP Address that allows it to be recognized by the router. Manually setup the device with a fixed IP address, for example, *192.168.1.100*.

(2) Access the Router with Your Web browser

The following steps generally apply to any router that you have on your network. The D-Link DI-624 is used as an example to clarify the configuration process. Configure the initial settings of the router by following the steps outlined in the router's **Quick Installation Guide**.

If you have cable or DSL service, you will most likely have a dynamically assigned WAN IP Address. 'Dynamic' means that your router's WAN IP address can change from time to time depending on your ISP. A dynamic WAN IP Address identifies your router on the public network and allows it to access the Internet. To find out what your router's WAN IP Address is, go to the **Status** screen on your router and locate the WAN information for your router. As shown on the following page the WAN IP Address will be listed. This will be the address that you will need to type in your web browser to view your camera over the Internet. Be sure to uncheck the **Reset IP address at next boot** button at the top of the screen after modifying the IP address. Failure to do so will reset the IP address when you restart your computer.

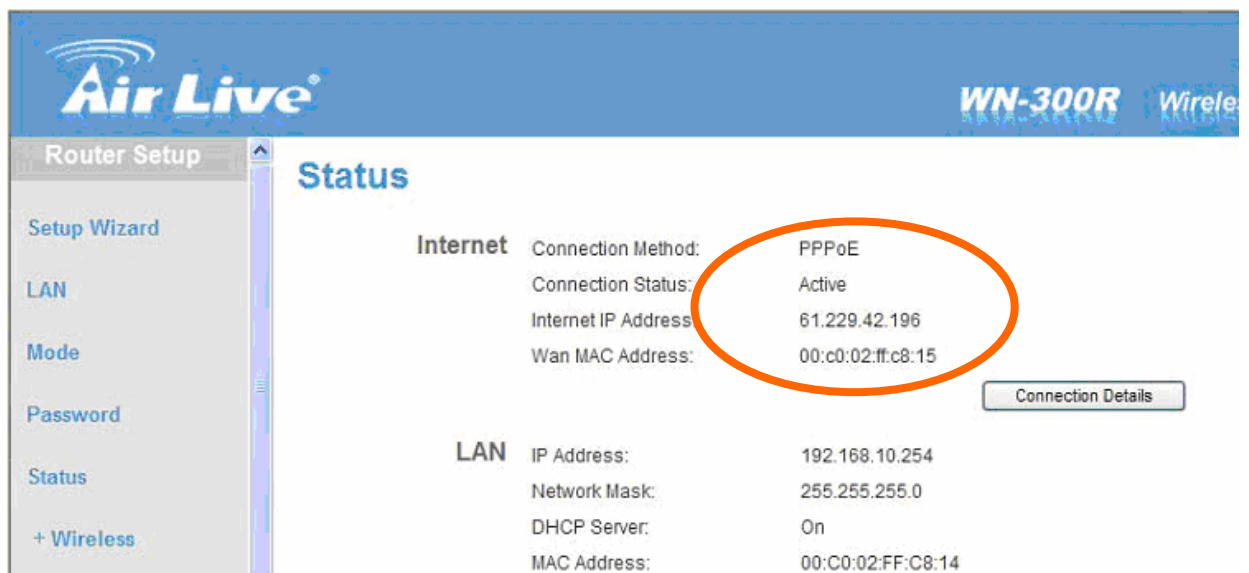

Your WAN IP Address will be listed here.

Note: Because a dynamic WAN IP can change from time to time depending on your ISP, you may want to obtain a Static IP address from your ISP. A Static IP address is a fixed IP address that will not change over time and will be more convenient for you to use to access your camera from a remote location. If you could not get a Static IP address from your ISP, the DIPS™ or DDNS is a solution alternatively. Please refer to Appendix G for more information.

(3) Open/set Virtual Server Ports to enable remote image viewing

The firewall security features built into the router and most routers prevent users from accessing the video from the device over the Internet. The router connects to the Internet over a series of numbered ports. The ports normally used by the device are blocked from access over the Internet. Therefore, these ports need to be made

accessible over the Internet. This is accomplished using the **Virtual Server** function on the router. The Virtual Server ports used by the camera must be opened through the router for remote access to your camera. Virtual Server is accessed by clicking on the **Advanced** tab of the router screen.

Follow these steps to configure your router's Virtual Server settings

- Click **Enabled**.
- Enter a unique name for each entry.
- Select **Both** under **Protocol Type (TCP and UDP)**
- Enter your camera's local IP Address (e.g., **192.168.1.100**, for example) in the **Private IP** field.
- If you are using the default camera port settings, enter **80** into the **Public** and **Private Port** section, click **Apply**.
- **Scheduling** should be set to **Always** so that the camera images can be accessed at any time.

A check mark appearing before the entry name will indicate that the ports are enabled.

Important: Some ISPs block access to port 80. Be sure to check with your ISP so that you can open the appropriate ports accordingly. If your ISP does not pass traffic on port 80, you will need to change the port the camera uses from 80 to something else, such as 8080. Not all routers are the same, so refer to your user manual for specific instructions on how to open ports.

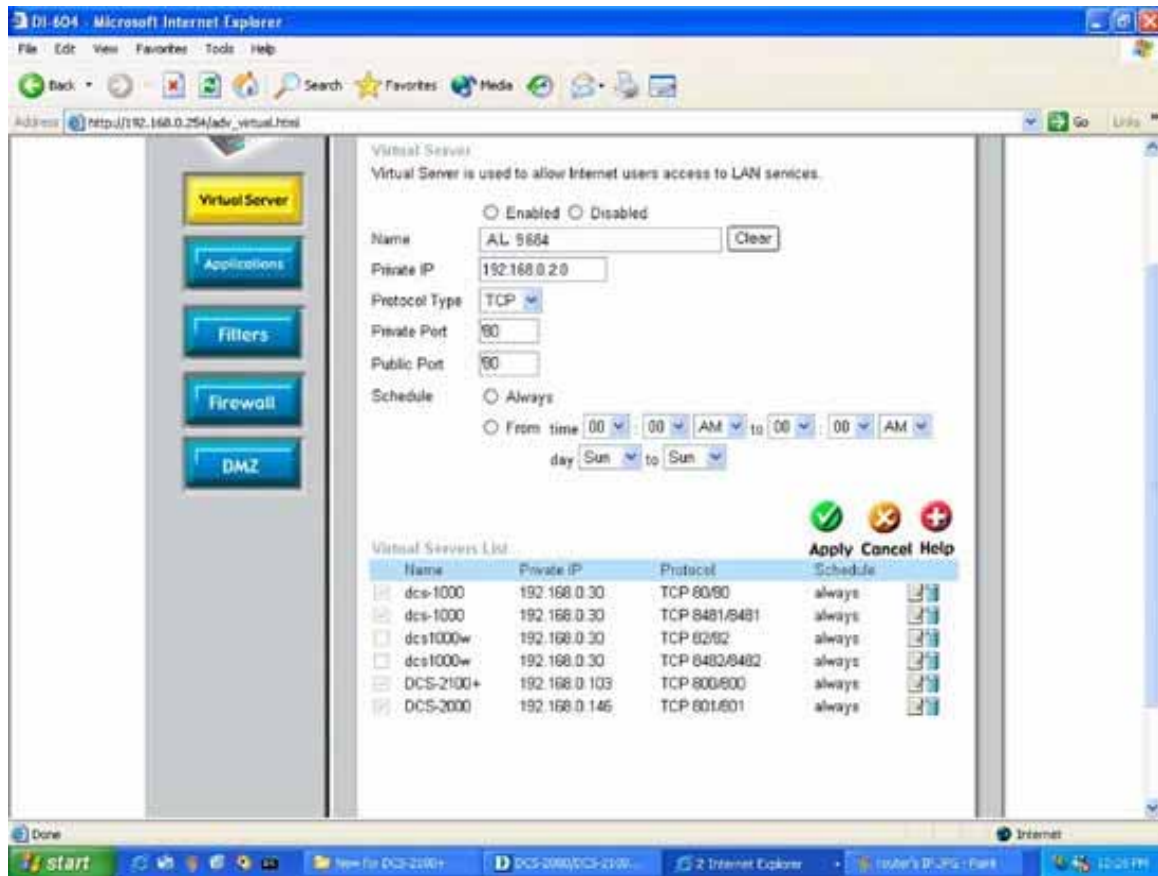

Enter valid ports in the **Virtual Server** section of your router. Please make sure to check the box on this line to enable settings. Then the device can be access from WAN by the router's WAN IP Address.

By now, you have finished your entire PC configuration for this device.

5.6 DDNS

1. Preface

If you have a Cable modem or xDSL, this is a great way to host your own Networked Device or other TCP/IP Service. Get your own domain like www.yourname.com, www.yourname.com.tw etc. (Note: This domain must be registered with Internic via registration authorities such as Network Solutions, DirectNIC, Register.com etc). Your domain name's dynamic IP address is automatically tracked by a DDNS server.

Host your own Networked Device and much more no matter what your computer's IP address may be and even if you have dialup, DSL or cable modem internet connection where your computer's IP address changes all the time!! DDNS service supports all top level domain names including but not limited to .com, .net, .org, .to, .uk etc.

2. Ethernet Network Environment

Normally, DDNS service is only necessary for the users that could only obtain dynamic IP addresses. As to the users that could obtain the static valid IP address, they do not usually have to apply the DDNS service. Before we decide if DDNS is necessary for the users, we have to check what kind of Ethernet network environment we have to install our Networked Device on.

(1) Environment of Fixed Valid IP Network

If users could obtain valid IP addresses, they could save the effort to apply DDNS service. Because the IP address in this environment is fixed, users could input the IP address or domain name of demo site directly in the IE browser.

(2) Environment of Dynamic IP Network

If users is under an environment of dynamic IP network (Dial-up xDSL), they have to apply a domain name in advance. Then apply DDNS service. Finally setup the necessary information of DDNS and PPPoE of the Networked Device in order to let the outside administrator be able to access through internet.

3. Application Steps—DDNS & Domain Name

- (1). Visit the following web site: <http://www.dyndns.org/>
- (2). Click “Account”



(3). After the columns show up at the left side, click [“Create Account”](#).



- (4). Fill the application agreement and necessary information.
 - a. Username
 - b. E-mail address and confirmation
 - c. Password and confirmation
 - d. Submit all the input information and finish creating an account

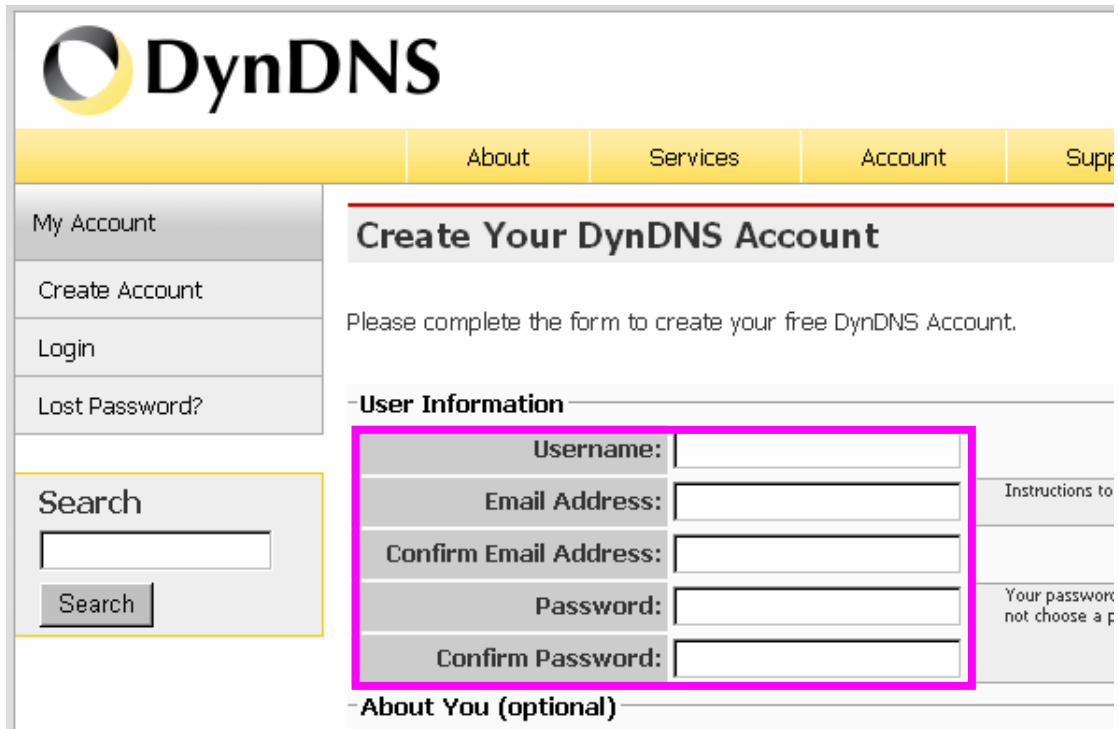

DynDNS

About Services Account Support

My Account

Create Account

Login

Lost Password?

Search

Search

Create Your DynDNS Account

Please complete the form to create your free DynDNS Account.

-User Information-

Username:

Email Address:

Confirm Email Address:

Password:

Confirm Password:

Instructions to

Your password not choose a p

-About You (optional)-

-Terms of Service-

Please read the acceptable use policy (AUP) and accept it prior to creating your account. Also acknowledge that you may only have one (1) free account, and that creation of multiple free accounts will result in the deletion of all of your accounts.

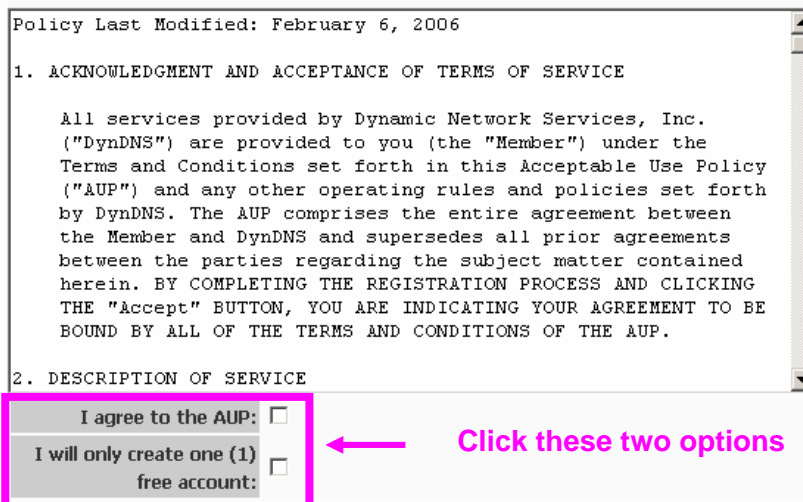

Policy Last Modified: February 6, 2006

1. ACKNOWLEDGMENT AND ACCEPTANCE OF TERMS OF SERVICE

All services provided by Dynamic Network Services, Inc. ("DynDNS") are provided to you (the "Member") under the Terms and Conditions set forth in this Acceptable Use Policy ("AUP") and any other operating rules and policies set forth by DynDNS. The AUP comprises the entire agreement between the Member and DynDNS and supersedes all prior agreements between the parties regarding the subject matter contained herein. BY COMPLETING THE REGISTRATION PROCESS AND CLICKING THE "Accept" BUTTON, YOU ARE INDICATING YOUR AGREEMENT TO BE BOUND BY ALL OF THE TERMS AND CONDITIONS OF THE AUP.

2. DESCRIPTION OF SERVICE

I agree to the AUP:

I will only create one (1) free account:

Click these two options

Next Step

After you click "Create Account", we will create your account and send you an e-mail to the address you provided. Please follow the instructions in that e-mail to confirm your account. You will need to confirm your account within 48 hours or we will automatically delete your account. (This helps prevent unwanted robots on our systems)

[Create Account](#)

(5). Check your e-mail mailbox. There will be an e-mail with a title "Your DynDNS Account Information". Click the hyperlink address to confirm the DDNS service that you just applied. Then DDNS you applied activated.

Your DynDNS Account 'kkkkk' has been created. You need to visit the confirmation address below within 48 hours to complete the account creation process:

https://www.dyndns.com/account/confirm/oDDGDYN75qTJk_ICGba6vQ **Click to confirm**

Our basic service offerings are free, but they are supported by our paid services. See <http://www.dyndns.com/services/> for a full listing of all of our available services.

If you did not sign up for this account, this will be the only communication you will receive. All non-confirmed accounts are automatically deleted after 48 hours, and no addresses are kept on file. We apologize for any inconvenience this correspondence may have caused, and we assure you that it was only sent at the request of someone visiting our site requesting an account.

Sincerely,
The DynDNS Team

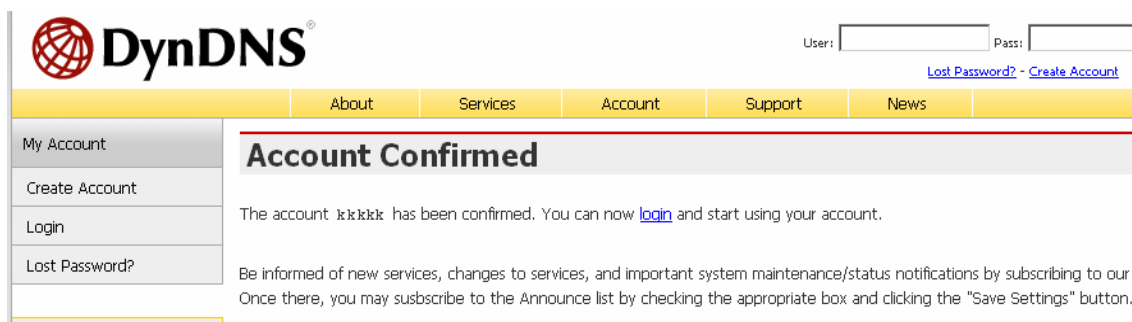

The screenshot shows the DynDNS website interface. At the top left is the DynDNS logo. To the right are input fields for 'User:' and 'Pass:' with links for 'Lost Password?' and 'Create Account'. Below this is a navigation bar with tabs for 'About', 'Services', 'Account', 'Support', and 'News'. On the left side, there is a 'My Account' menu with options for 'Create Account', 'Login', and 'Lost Password?'. The main content area displays a large heading 'Account Confirmed' followed by the text: 'The account kkkkk has been confirmed. You can now [login](#) and start using your account.' Below this, there is a section for subscribing to announcements, stating: 'Be informed of new services, changes to services, and important system maintenance/status notifications by subscribing to our. Once there, you may subscribe to the Announce list by checking the appropriate box and clicking the "Save Settings" button.'

(6). Enter the web page <http://www.dyndns.org/> again. Input your username and password that you just applied to login administration interface of DDNS server.

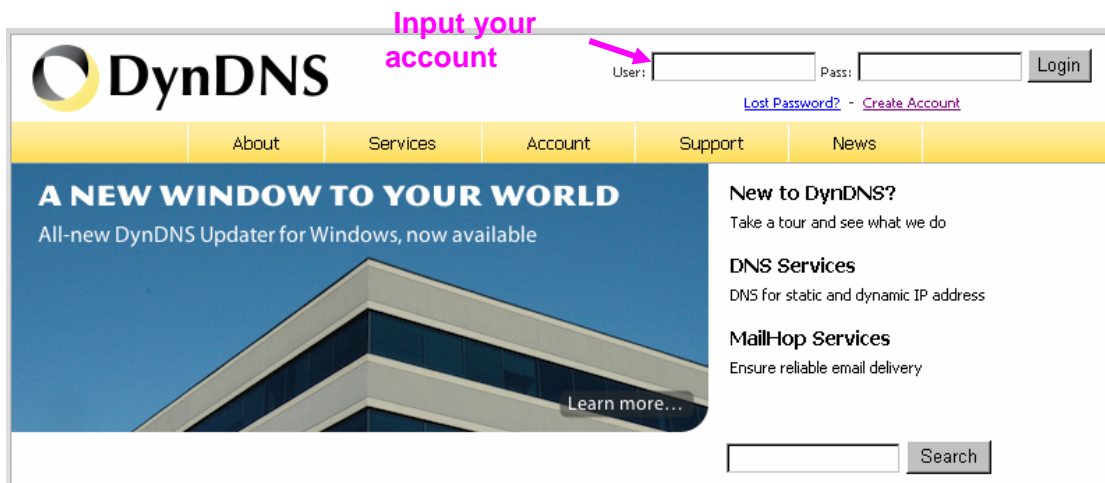

(7). If the correct username and password are input, you can see the following picture at the top-right of the login page.

(8). Click the “[Services](#)”.

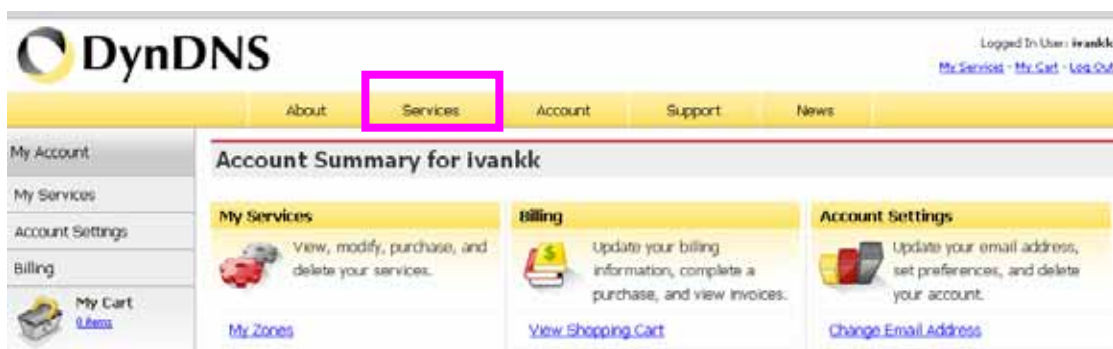

(9). Click the “[Dynamic DNS](#)”.

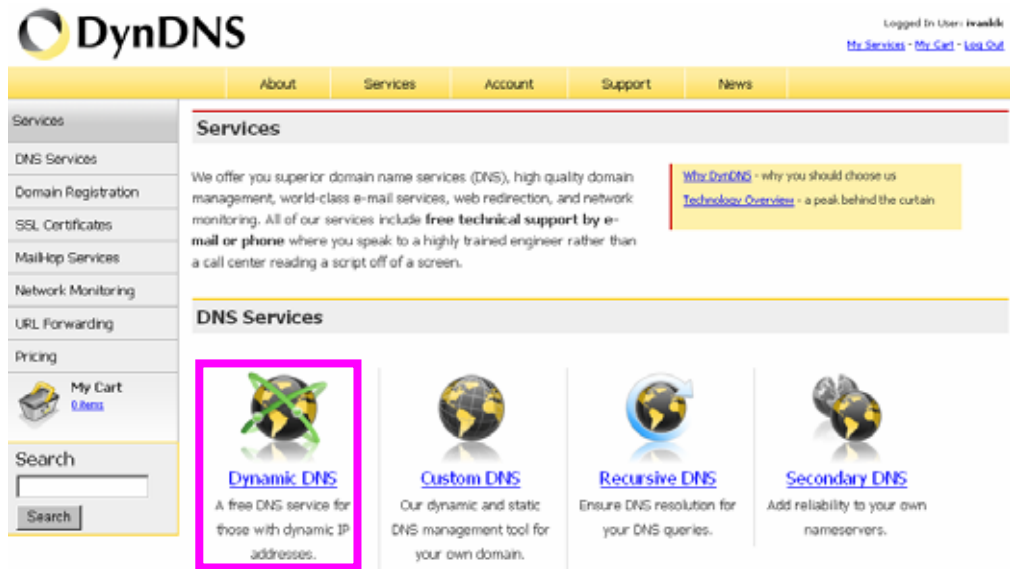

(10). Click the “Get Started”.

Dynamic DNS

Dynamic DNS (DDNS) allows you to create a hostname that points to your dynamic IP or static IP address or URL. We also provide an update mechanism which makes the hostname work with your dynamic IP address. **We continue to offer this service free** to the Internet community as we have done so **for nearly 10 years**.

Capabilities and Features

- Get five (5) hostnames in [88 available domains](#) for free.
- Create wildcard CNAME **,yourhost.dyndns.org* for *yourhost.dyndns.org*.
- Forward web requests or mark host offline for maintenance or downtime.
- Configure MX records for flexible mail routing.
- Update host using [ddns update clients](#) for a wide variety of platforms.
- Modify DNS TTL values for fast propagation or reliable static IP caching.
- Deliver your DNS records to 5 DNS servers in 5 tier-1 datacenters around the globe.
- Query volume up to 648,000 queries/month

Our **free industry-leading e-mail support** is ready to help you setup your dynamic or static DNS so you can host a website, remotely connect to your machine, and run a mail server. We also offer other premium features with our [Account Upgrade](#) service.

Get Started

Manage Hosts

Screenshot

(11). We could create a domain name without any charge at this step. First, we input the host name. (Pink No.1) Then we pick a domain that is easy to remember. (Pink No.2) The 3rd step is to click “Offline Hostname” from Service Type. (Pink No.3) Finally, click the “Create Host” to submit the domain name information and finish DDNS application. (Pink No.4)

Add New Hostname [↑ Host Services](#)

Note: You currently don't have Account Upgrades in your account. You cannot use some of our Host Service features. Please consider buying Account upgrade that make this form full-functional and will add several other features. [Learn More...](#)



1 → Hostname: dyndns.org ← 2

Wildcard: Yes, alias "*.hostname.domain" to same settings.

Service Type:

- Host with IP address
- WebHop Redirect
- Offline Hostname

3 →

IP Address:

[Use auto detected IP address 118.168.38.166.](#)

TTL value is 60 seconds. [Edit TTL.](#)

Please enter valid IP address (optional for Offline hostnames).

Mail Routing: Yes, let me configure Email routing.

4 ↓

4. Setup the DDNS and PPPoE of Networked Device

At last, users have to enter the web page of Networked Device and setup the necessary information of DDNS and PPPoE after the application of DDNS service. Please check the user manual to access the DDNS and PPPoE pages. After saving the modification, restart the device. Then the external users could browse the Networked Device by the input of their domain name.

5.7 Power Line Frequency

COUNTRY	VOLTAGE	FREQUENCY	COMMENTS
Argentina	220V	50 Hz	*Neutral and line wires are reversed from that used in Australia and elsewhere.
Australia	230V*	50 Hz	*Outlets typically controlled by adjacent switch. Though <i>nominal</i> voltage has

			been officially changed to 230V, 240V is within tolerances and commonly found.
Austria	230V	50 Hz	
Brazil	110/220V*	60 Hz	*127V found in some states. Please check with your state electricity company.
Canada	120V	60 Hz	
China, People's Republic of	220V	50 Hz	
Finland	230V	50 Hz	
France	230V	50 Hz	
Germany	230V	50 Hz	
Hong Kong	220V*	50 Hz	
India	230V	50 Hz	
Italy	230V	50 Hz	
Japan	100V	50/60 Hz*	*Eastern Japan 50 Hz (Tokyo, Kawasaki, Sapporo, Yokohama, and Sendai); Western Japan 60 Hz (Osaka, Kyoto, Nagoya, Hiroshima)
Malaysia	240V	50 Hz	
Netherlands	230V	50 Hz	
Portugal	230V	50 Hz	
Spain	230V	50 Hz	
Sweden	230V	50 Hz	
Switzerland	230V	50 Hz	
Taiwan	110V	60 Hz	
Thailand	220V	50 Hz	
United Kingdom	230V*	50 Hz	*Outlets typically controlled by adjacent switch. Though <i>nominal</i> voltage has been officially changed to 230V, 240V is within tolerances and commonly found.
United States of America	120V	60 Hz	

5.8 3GPP Table

To use the 3GPP function, in addition to previous section, you might need more information or configuration to make this function work.

Note that to use the 3GPP function, it strongly recommends to install the Networked Device with a public and fixed IP address without any firewall protection.

RTSP Port:

Port 554 is the default for RTSP service. However, sometimes, some service providers change this port number for some reasons. If so, user needs to change this port accordingly.

Dialing procedure:

1. Choose a verified player (PacketVideo or Realplayer currently)
2. Use the following URL to access:

<rtsp://host/mpeg4/media.3gp>

Where *host* is the host name or IP address of the camera.

Compatible 3G mobile phone:

Please contact your dealer to get the approved list of compatible 3G phone.

5.9 UPnP

Use the following steps to enable UPnP settings only if your operating system of PC is running Windows XP.

Go to **Start > Settings**.

Click **Control Panel**

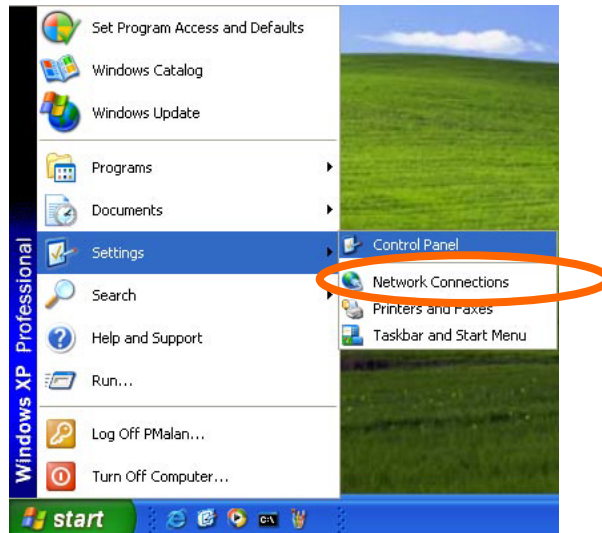

Click **Add or Remove Programs**



Click **Add/Remove Windows Components**

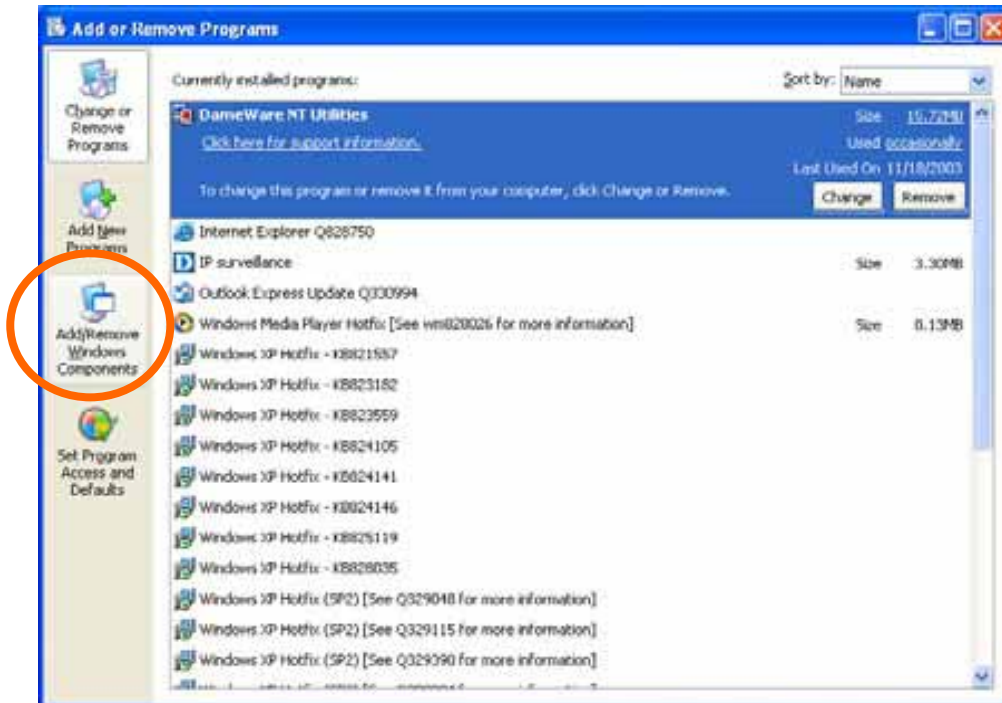

The following screen will appear:
Select **Networking Services**

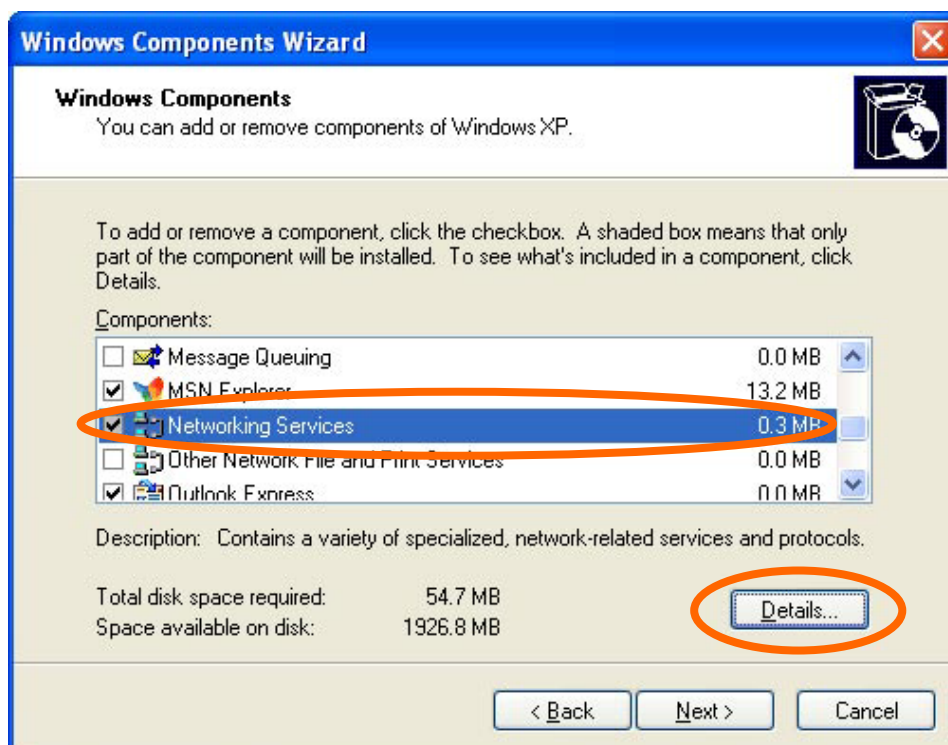

Select Universal Plug and Play

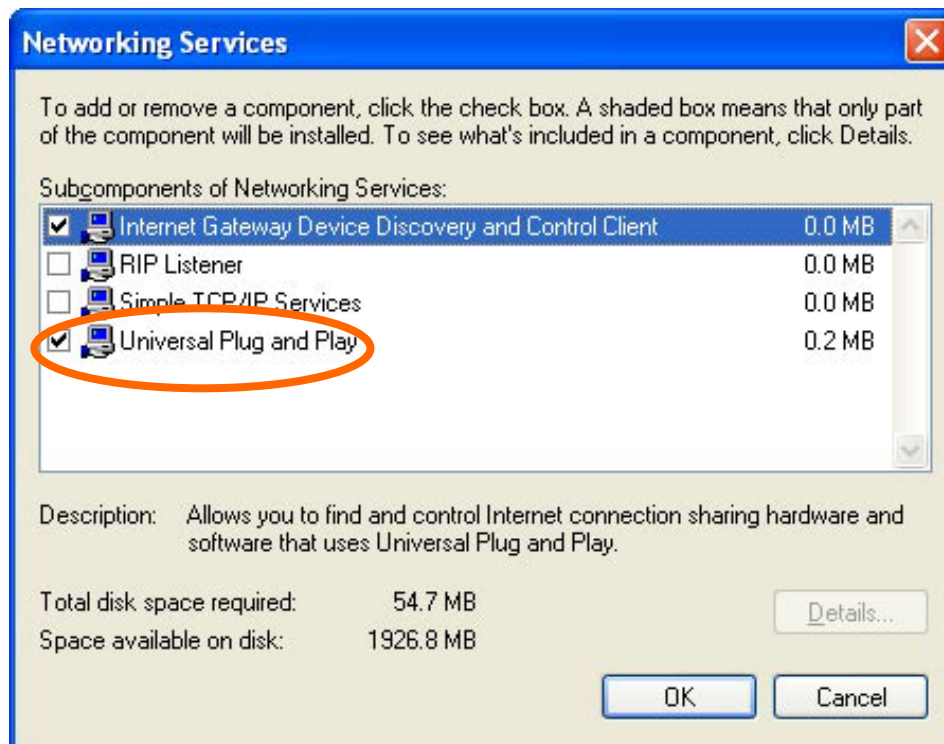

Click Details

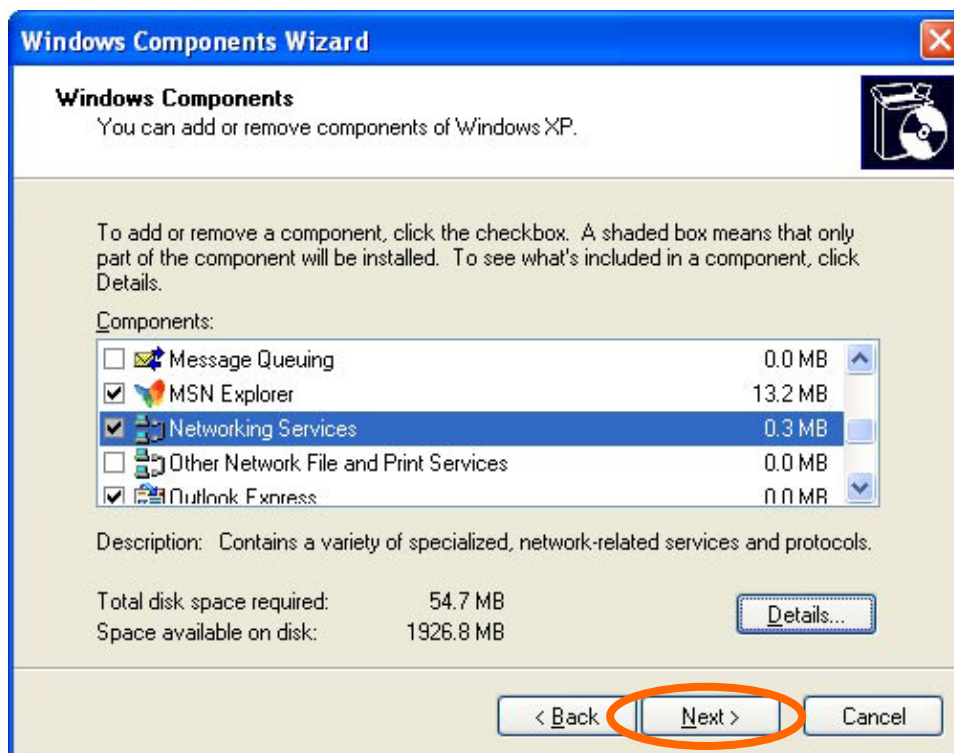

Click Next

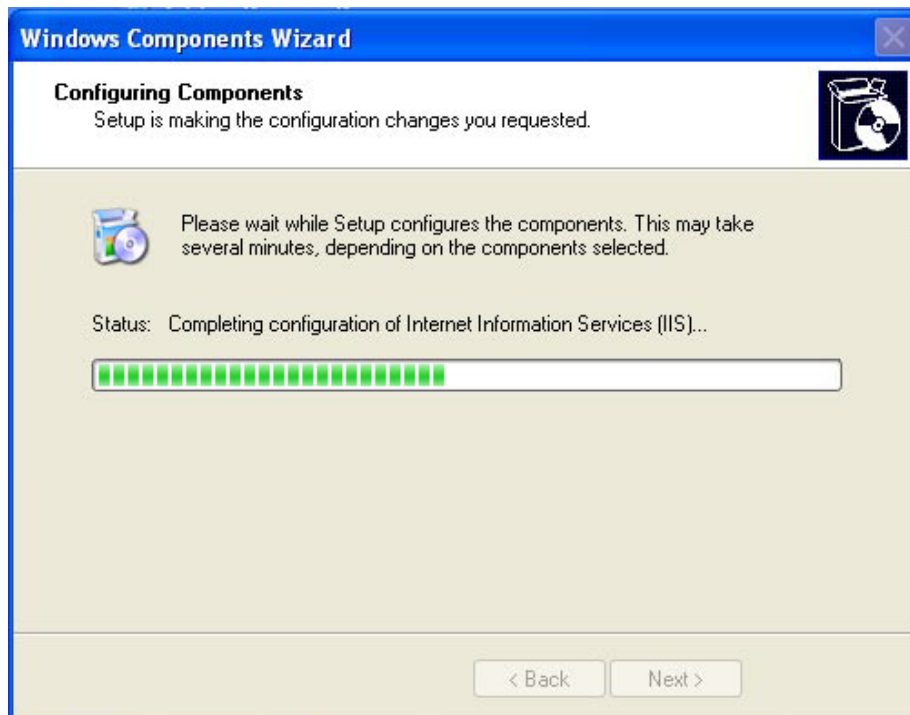

Please wait while Setup configures the components.



Click **Finish**